

MIDAS

CIVIL NX 2026 (v2.1)

Release Note

Insanely Fast.
Boundlessly Capable.
Beyond Your Engineering Struggles.

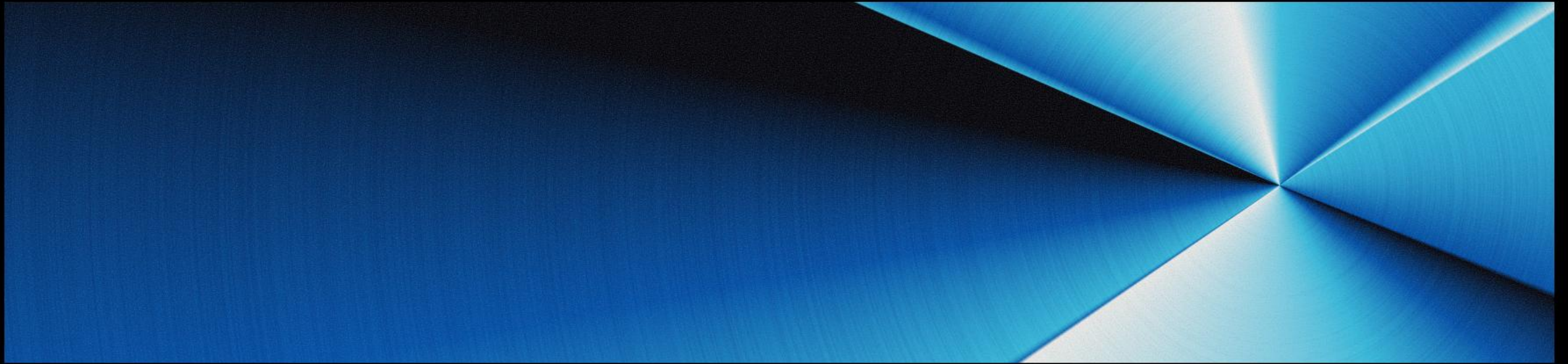

Table of Contents



01 Hyper-S Analysis Engine

- Selective Analysis
- Easy Boundary Condition Changes
- Geometric & Material Nonlinearity per Load Case
- Dedicated Workspace for Time History Analysis
- Geometric & Material Nonlinear Analysis for Construction Stage
- Buckling Analysis During Construction Stages
- Results Available Even After Abnormal Termination
- Major Algorithm Improvements in Hyper-s Engine

02 Virtual Beam Design

- Virtual Beam Design Capability

03 Localization for New Markets

- Localized UI and Design Reports for New Market Expansion

04 Enhanced Design Code Support

- AASHTO LRFD 2024 Implementation
- Enhanced Localization for Australia & New Zealand
- Enhanced Localization for Malaysia
- Enhanced Localization for Canada
- Enhanced Localization for Brazil

05 Enhanced Seismic Analysis

- Fiber Hinge Support for Pushover Analysis
- Enhanced Pushover Curve design spectrum
- Point Spring Support added to Inelastic Hinge Properties

06 Enhanced Railway Bridge Capabilities

- Expanded Rail-Structure Interaction Capabilities

07 Improved Modeling Productivity

- Tracing-Based Modeling
- Refined Element Type Classification for More Intuitive Local Axis Definition
- Customization of Message Window and Toolbar

08 Performance Improvements

- Performance Improvement
- File Open/Save speed
- File Open Error Skip System
- View Selection
- View Performance Expansion
- Result Table Performance and Active Dialog Improvement

Table of Contents



09 Convergence & Advanced Analysis Control

Numerous convergence-related options added to Main Control

Enhanced Convergence Control for Non-linear CS Analysis

Added convergence-related options for Heat of Hydration

Enhanced Control for Time History Analysis: New Time Integration Option and Refined Convergence Criteria

Enhanced Pushover Analysis Controls and Convergence Options

Added multi-processor and equation solver options in Analysis Option

Improved Lumped Mass Options in the Structural Type settings

10 Property Separation for Selective Analysis

Separated Inelastic Hinge Properties for General Links

Independent Output Control Section in Time History Global Settings

Automatic Fiber Section Generation with Dedicated Inelastic Material Link

01

HYPER-S Analysis Engine

Designing the Future with Innovative Engineering Solutions





Selective Analysis

Optimizing iterative analysis and design workflows by selectively performing specific analysis/load case.

- Previous: All analyses had to be executed in full when running a simulation.
- CIVIL NX 2026 (v2.1): Analyses can now be executed selectively by analysis type and load case. However, since linear static analysis does not require significant computation time, it is performed in a single run without separation by load case.
- Enhanced Efficiency in Nonlinear Analysis: In particular, this enhancement significantly improves workflow efficiency for time history analysis, pushover analysis, geometric/material nonlinear analysis, and moving load analysis.

The image displays three overlapping screenshots of the 'Perform Analysis' dialog box, illustrating the 'Analysis & Load Cases' section. Each dialog has a table with columns: Select, Analysis & Load Cases, Type, Restart from Stage, and Status.

Top Dialog: Shows 'Construction Stage Analysis' (Construction Stage, Construction Stage, Not Executed) and 'Static Analysis' (Static Load, Static, Not Executed). The 'Static Analysis' row is selected.

Middle Dialog: Shows 'Construction Stage Analysis' (Construction Stage, Construction Stage, Completed), 'Static Analysis' (Static Load, Static, Completed), 'Influence Line/Surface Analysis' (Influence, Moving, Completed), 'Moving Load Analysis' (LM1_1.0TS+1.0UDL, Moving, Completed) and (LM1_0.75TS+0.4UDL, Moving, Completed), and 'Settlement Analysis' (Settlement, Settlement, Completed). The 'Moving Load Analysis' rows are selected.

Bottom Dialog: Shows 'Static Analysis' (Static Load, Static, Completed), 'Eigenvalue Analysis' (Eigenvalue, Linear Dynamic, Completed), and 'Time History Analysis' (DEAD, Nonlinear Time History, Completed) through (HIS7, Nonlinear Time History, Completed). The 'Time History Analysis' rows are selected.



Easy Boundary Condition Changes

Improving usability by enabling clearer workflow separation and more control over boundary condition variations.

- Previous:
Boundary Combination definition and assignment to load cases were handled within a single integrated dialog, making it less intuitive to distinguish between definition and application steps.

- CIVIL NX 2026 (v2.1):
The workflow has been restructured by separating the dialog for defining Boundary Combinations from the dialog used to assign them to load cases and analyses. In addition, boundary condition items to be applied or excluded can now be explicitly selected during assignment, improving clarity and control over boundary change configurations.

- The range of boundary change items has also been expanded, providing greater flexibility and control in defining boundary condition variations across analyses.

- Surface Spring Support
- Rigid Link
- Elastic Link
- and more

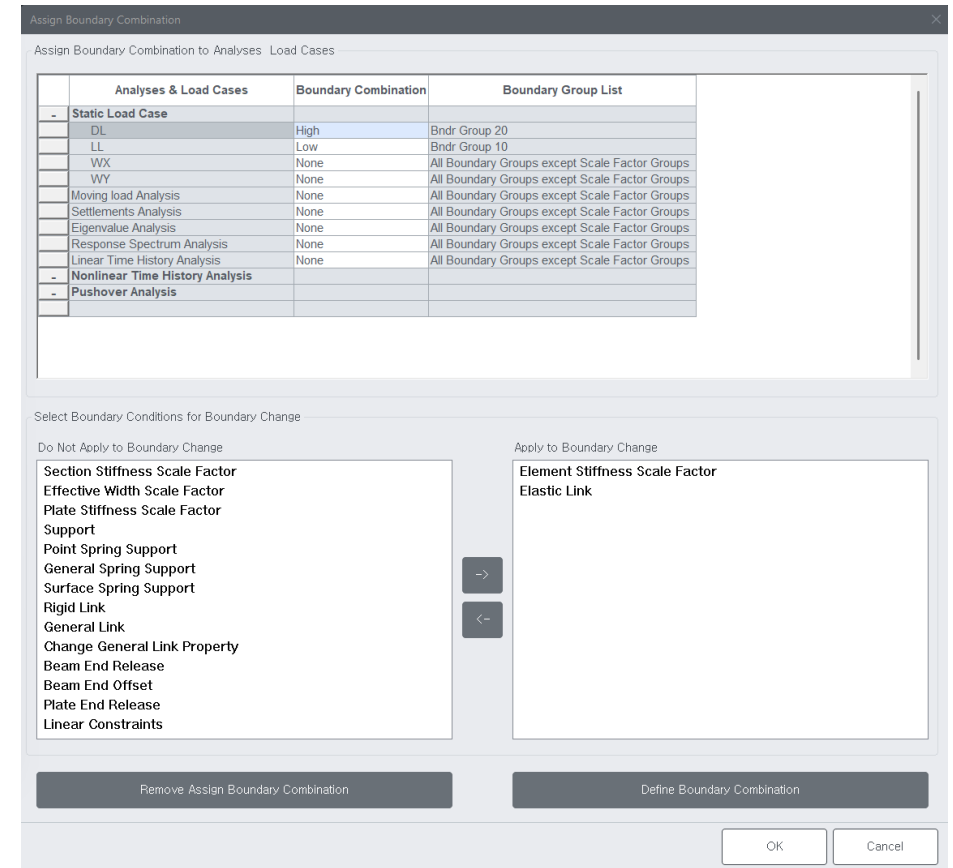
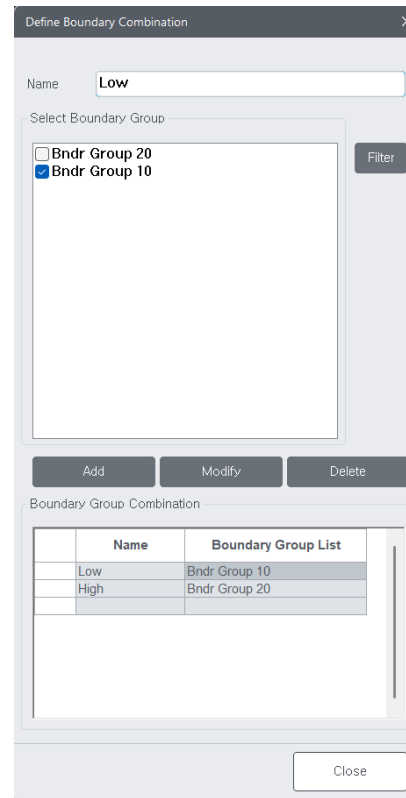

Geometric & Material Nonlinearity per Load Case

Maximizing Review Efficiency for Complex Nonlinear Models through Individual Control of Case-Specific Nonlinear Properties.

- Previous: Geometric and material nonlinear analysis was performed for all static load cases.
- CIVIL NX 2026 (v2.1): Users can now select which load cases to run as linear analysis and which to run as nonlinear analysis.
- Enhanced Nonlinear Control UI: In addition, advanced nonlinear convergence control options—such as stiffness update schemes, line search, and bisection controls—have been introduced, resulting in improved convergence performance and analysis stability.

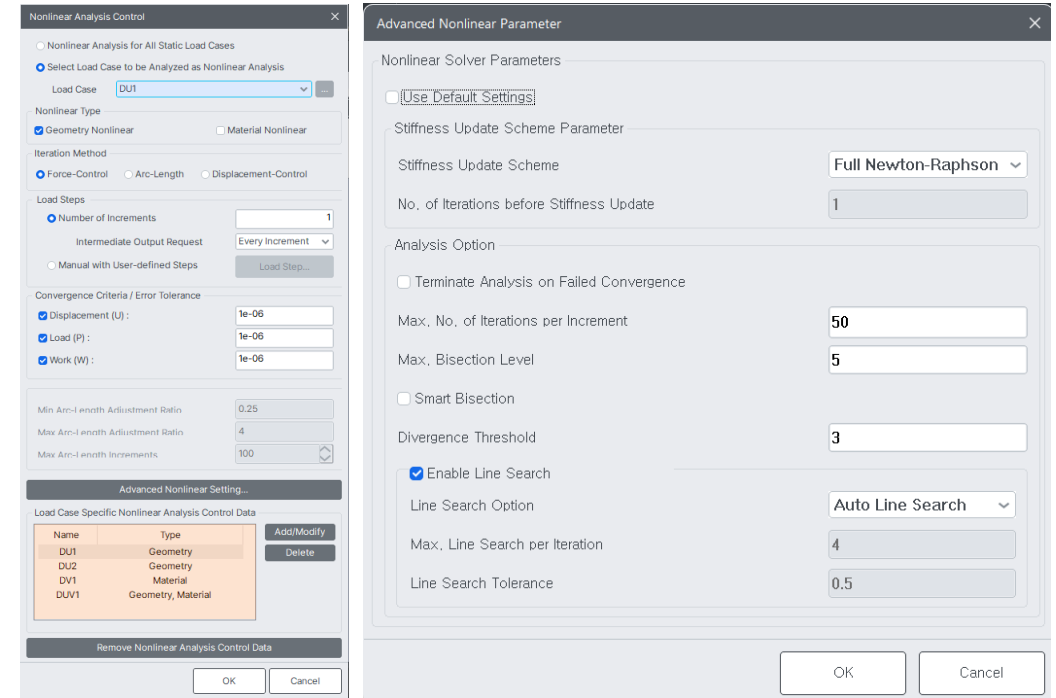

Dedicated Workspace for Time History Analysis

Optimized Efficiency and Focus in Complex Dynamic Analysis with a Dedicated Time History Analysis Workspace.

- Dedicated Ribbon Menu and Workspace for Time History Analysis: A dedicated Time History ribbon menu has been introduced, consolidating all essential functionalities—from modeling to result review—into a single interface, improving accessibility and workflow efficiency for time history analysis users.

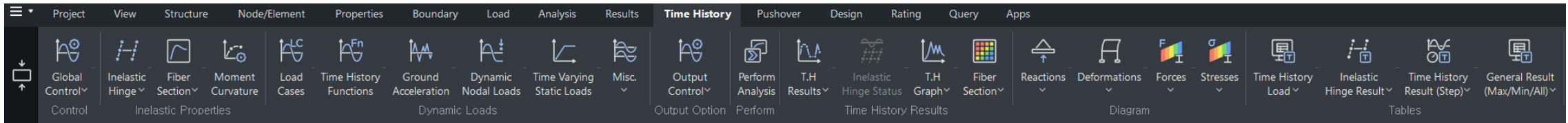

Geometric & Material Nonlinear Analysis for Construction Stage

Enabling more accurate and realistic prediction of structural behavior during construction stages.

- Combined Nonlinear Construction Stage Analysis: Construction stage analysis has been enhanced to allow simultaneous consideration of geometric and material nonlinear effects, enabling more realistic and accurate simulation of structural behavior during staged construction.

Construction Stage Analysis Control Data

Final Stage
 Last Stage Other Stage

Restart Construction Stage Analysis

Analysis Option
Analysis type: **Linear Analysis** (dropdown menu open showing: Linear Analysis, Geometric Nonlinear Analysis, Material Nonlinear Analysis, **Geometric/Material Nonlinear Analysis**)
 Independent
 Include Effects
 Include P-Delta Effect
 Include Time Dependent Effect

Load Cases to be Distinguished from Dead Load for C.S. Output

No	Load Case Name	Type	Case1	Case2	Add

Buttons: Modify, Delete

Cable-Pretension Force Control
 Internal Force External Force

Initial Force Control
 Convert Final Stage Member Forces to Initial Forces for Post C.S.
 Truss Beam

Initial Displacement for C.S.
 Change Cable Element to Equivalent Truss Element for Post C.S.
 Apply Initial Member Force to C.S.
 Initial Tangent Displacement for Erected Structures
 All Group

Beam Section Property Changes
 Constant Change with Tendon

Frame Output
 Calculate Concurrent Forces of Frame
 Calculate Output of Each Part of Composite Section
 Self-Constrained Forces & Stresses

Buttons: OK, Cancel

Geometric & Material Nonlinear Analysis for Construction Stage



Buckling Analysis During Construction Stages

Maximizing Construction Safety and Design Reliability through Integrated Buckling Stability Reviews by C.S.

- Buckling analysis can now be performed for a specified construction stage. Users can evaluate buckling loads at a particular stage and account for geometric stiffness effects (P-Delta) during construction to determine buckling capacity under given loading conditions.
- Integrated Buckling Analysis for Construction Stages: Enables buckling stability reviews directly within construction stages without separate model files, ensuring consistency and enhancing productivity.
- Support for Transient Construction Stage Loads (TCS): Reflects transient loads like storm or eccentric loading that occur only at specific stages and do not accumulate in subsequent stages.

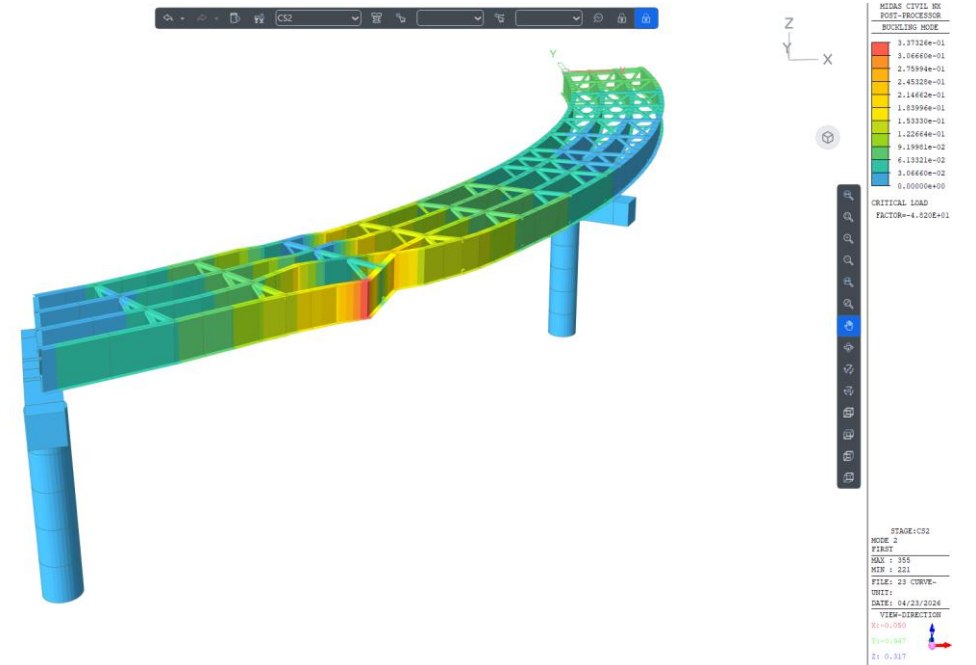

Buckling Analysis During Construction Stages

Maximizing Construction Safety and Design Reliability through Integrated Buckling Stability Reviews by C.S.

- Steps to perform buckling analysis using the stiffness of Stage 14 to find buckling load factor for the storm loads.
- Step 1. Define a load case, STORM whose load type is Transient Construction Stage Load (TCS). Storm load does not have to be applied at Stage 14.
- Step 2. Click the Add. Analysis button to define Construction Stage Buckling Control.
- Step 3. Select Stage 14 and add CS: Summation as Constant load type and ST: STORM as Variable.
- Step 4. Check buckling load factors and buckling modes at Stage 14.

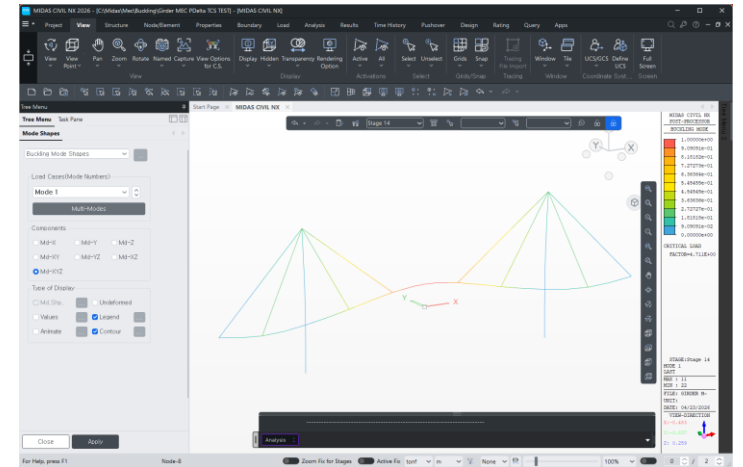
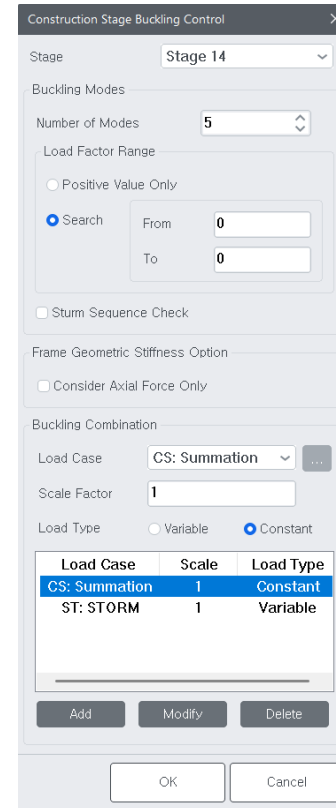
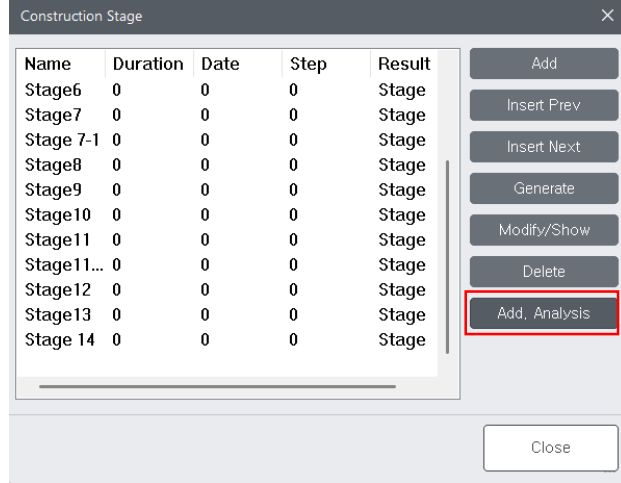
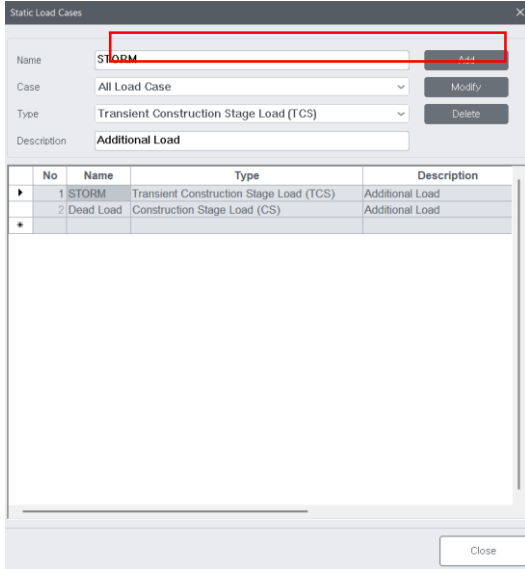

Results Available Even After Abnormal Termination

Maximizing Stability and Efficiency for Long-duration Analyses through Data Continuity and Restart Capabilities.

- Preservation of Converged Results: Data up to the "Last Converged Point" is retained and accessible even after abnormal terminations or manual interruptions.
- Visualization of Step-specific Reliability: In nonlinear and time-history analyses, results are displayed based on successfully converged steps.
- Post-Termination Verification: Results can be extracted from the last completed static case or nonlinear step even if the whole analysis process analysis is incomplete. It supports rapid root-cause analysis and real-time feedback.

Major Algorithm Improvements in Hyper-s Engine

Enhanced Accuracy and Convergence through High-Precision Hybrid Algorithms and End-to-End Parallel Optimization

- Improved Element Algorithms: Added advanced Hybrid algorithm for Plate/Solid members to improve stress accuracy.
Enhanced equivalent truss calculations by considering initial length conditions.
- Enhanced Eigenvalue Accuracy & Functions: Improved accuracy for lumped mass models by considering off-diagonal mass terms.
Enabled use of consistent mass with the Ritz Vector method.
- Advanced Nonlinear Convergence & Accuracy: Added stiffness update options: Full Newton, Modified Newton, and Initial Stiffness.
Improved convergence with Bisection and Line-search methods.
Expanded simultaneous material/geometric nonlinearity support to Truss and Solid elements.
- New Nonlinear Time History Features: Added HHT- α integration method for numerical damping of high-frequency responses.
Added Damping Update Control options. Applied the same stiffness update methods used in static nonlinear analysis.
Added Dormand-Prince method for boundary nonlinearity analysis.
Improved initial hinge state evaluation considering initial member forces.
- Enhanced Release Algorithm: Replaced penalty-stiffness condense method with MPC-based release formulation for higher accuracy in complex conditions, including partial DOF releases, geometric nonlinearity, and hinge rotations.

02

Virtual Beam Design

Designing the Future with Innovative Engineering Solutions





Virtual Beam Design Capability

Enhancing Complex Design via Plate-based Analysis and Global Standard Integration.

- Previous : Virtual beam design was supported only for models generated by the steel composite girder wizard.
- CIVIL NX 2026 (v2.1) : Virtual beam design is now also supported for manually defined virtual beams. In addition, for PSC composite girders, design is supported for both wizard-generated and manually defined virtual beams.
- Plate Element-Based Design: Incorporates 2D local stresses and joint behaviors directly into the design process. This supports a high-precision analysis environment.
- Implementation of Global Design Codes

Previous Version: Steel Composite Design: AASHTO LRFD

Steel Composite Rating: CS454

New Version : PC Composite Design: AASHTO LRFD, Eurocode 2

Steel Composite Design: Eurocode 4

Steel Composite Rating: AASHTO LRFR

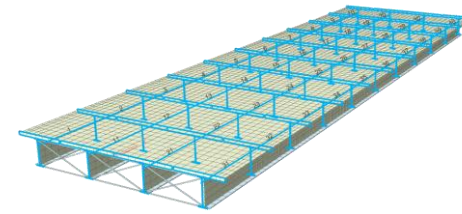

Steel Composite

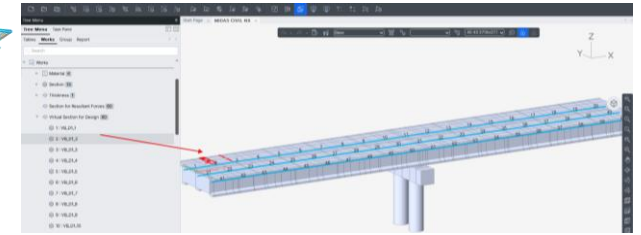

PC Composite

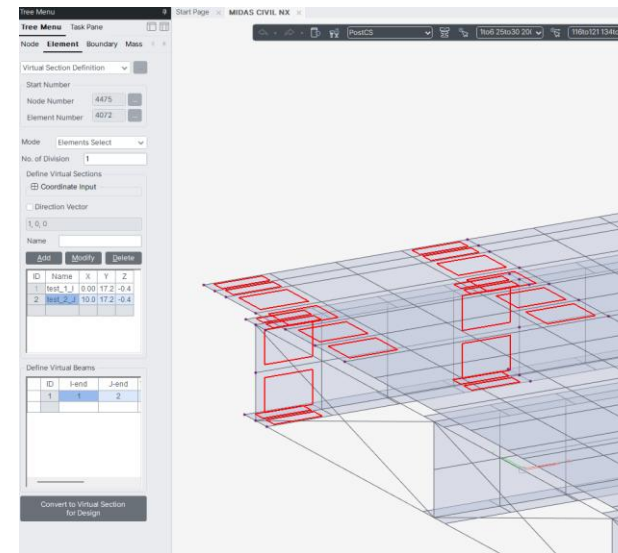

2.Ultimate Moment Resistance

Positive Moment

1. Check Moment Resistance, M_{uR}

Load Combination Name: cLCB1
 Design Situation: Persistent & Transient
 Load Combination Type: FX-MAX
 $M_{uR} = 1297.471$ kN-m

Factor λ , and factor η

$\lambda_{s1} = 0.900$ ($f_{cd} \leq 50$ MPa)
 $\lambda_{s2} = 0.900$ ($f_{cd} \leq 50$ MPa)
 $\lambda_{st1} = 1.000$ ($f_{td} \leq 50$ MPa)
 $\lambda_{st2} = 1.000$ ($f_{td} \leq 50$ MPa)

Design strength of concrete (EN 1992-1-1:2004, 3.1.6(1))

Girder: $f_{cd,con} = \lambda_{s1} \cdot f_{cd,con} / \gamma_c = 22.667$ MPa
 Slab: $f_{cd,slab} = \lambda_{s2} \cdot f_{cd,slab} / \gamma_c = 17.000$ MPa

Design strength of Reinforcement (EN 1992-1-1:2004, 3.2.7)

Girder: $f_{td,con} = f_{td,con} / \gamma_s = 434.783$ MPa
 Slab: $f_{td,slab} = f_{td,slab} / \gamma_s = 434.783$ MPa

Calculate Neutral Axis

- 1) Assume neutral axis depth.
- 2) Calculate the strain of steel and tendon.
- 3) Calculate the stress of steel and tendon.
- 4) Calculate the axial force in concrete, steel, and tendon.
- 5) Check if the resultant force of cross-section is zero.
- 6) Repeat step 1 through 5 until the resultant force becomes zero.

Num.	Neutral depth (mm)	Compression Force (C) (kN)	Tension Force (T) (kN)	Ratio (C/T)
1	1442	2550412	2550412	1.94474
2	1442	2550412	2550412	0.76352
3	1442	2550412	2550412	1.29450
4	1442	2550412	2550412	1.91589
5	1442	2550412	2550412	0.97400
6	1442	2550412	2550412	1.00000
7	1442	2550412	2550412	0.97400
8	277.734	277.734	277.734	1.00000

Calculate F_{cp} , F_{sp} , F_{st} , F_{st}

$F_{cp} = \lambda_{s1} \cdot \lambda_{s2} \cdot f_{cd,con} \cdot A_{con} = 2246$ kN
 $F_{sp} = \lambda_{s1} \cdot \lambda_{s2} \cdot f_{cd,con} \cdot A_{slab} = 295.043$ kN
 $F_{st} = f_{td,con} \cdot A_{st} = 0.000$ kN
 $F_{st} = f_{td,slab} \cdot A_{st} = 3152.156$ kN

where: $\beta = \lambda \cdot x = 222.188$ mm
 $x = 277.734$ mm neutral axis depth
 $A_{con} = 24690.063$ mm² Area of rectangular concrete
 $A_{slab} = 141750.142$ mm² Area of rectangular concrete
 $A_{st} = 678.600$ mm² Compression reinforcement area
 $A_{st} = 0.000$ mm² Tension reinforcement area

Manual Virtual Beam Design

03

Localization for New Markets

Designing the Future with Innovative Engineering Solutions

Localized UI and Design Reports for New Market Expansion

Maximizing Global Competitiveness and Efficiency through UI Localization and Automated Multi-language Design Reporting.

- Full Workflow UI Localization: Language barriers are eliminated by applying multi-language interfaces to all menus, ribbons, and dialogs. This ensures seamless data input and result verification.
- Automated Multilingual Design Reports: Submission processes for local authorities are optimized by automatically generating reports with localized text, table titles, and status indicators.
- Integration with 23 Global Design Codes: Responsiveness to regional regulations is enhanced by combining localized outputs with analysis and design capabilities for 23 international standards.
- Expanded Language Support: Market entry into Southeast Asia and Europe is accelerated with UIs in Italian, Polish, and French, plus report generation in languages like Taiwanese, Vietnamese, and Thai.
- Consistent Language Management: A unified language environment is maintained from setup to final documentation. This prevents configuration errors and improves decision-making accuracy.
- Reduced Lead Time and Training Costs: Operational efficiency is boosted by enabling local engineers to immediately manage models and generate reports in their native language, minimizing training needs.

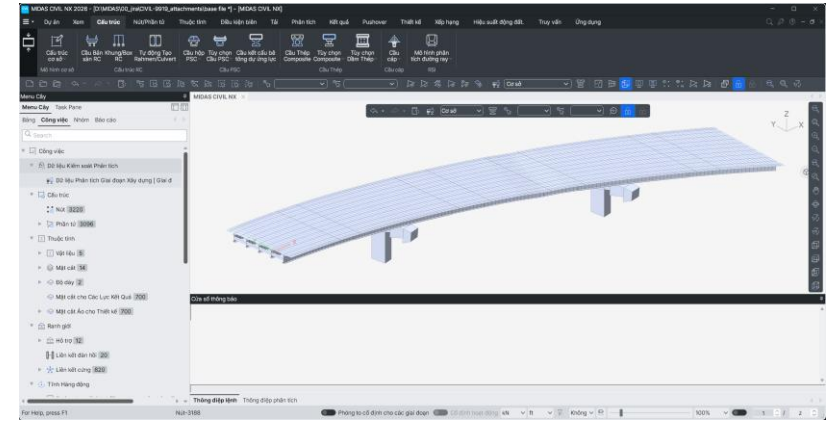

Multi-language interface support

■ ข้อมูลอาคาร : G4 (Section ID : 414, Element No.398)

1. ข้อมูลอาคาร

1) รหัสอาคาร
AC118-19

2) รหัสอาคาร
G4 (ID : 414)

3) ชื่อ
อาคาร
 $F_x = 17236.899kN, F_y = 19350364.403kN$
น้ำหนัก
 $F_z = 400.000.000kN, F_x = 400.000.000kN, F_y = 199.948.023.746kN$

4) ระยะ
 $L = 9.000m$

5) รูปถ่ายอาคาร

6) ข้อมูลอาคารตามแบบแปลน (ตามแบบแปลน)
อัตราส่วนคาน/เสา = 0.850

2. ตารางตามการคำนวณ (กฎ) (Sector I, 0.00R)

$M_x / \alpha M_u$	101.0864Nm / 373.493Nm = 0.272	OK
P_{max} / P_{lim}	$P_{max} = 0.00146$ $P_{lim} = 0.00420$ $P_{lim} = 0.00288$	OK

1) ข้อมูลอาคารตามแบบแปลน

$\alpha = 0.850$	$b_w = 0.550m$	$h = 0.800m$
$d = 0.724m$	$d_s = 0.976m$	$A_s = 0.00152m^2$
$A_s = 0.00173m^2$	$b_w = 0.800m$	$\rho = 0.0050$
$\rho = 0.0050$	$k = 1.00$	$F_x = 0.850 (F_x = 27.576.058kN)$

2) ตารางตามการคำนวณตามแบบแปลน (ตามแบบแปลน)

$F_x = \frac{2}{3} F_x = 266.666.667kN$
$F_y = 0.0035m$

Preferences dialog box showing settings for Environment, General, View, Data Tolerances, Property, Load, Results, Design/Load Code, Display/Notice, Graphics, Output Formulas, and Report Language. The Report Language dropdown is set to Thai.

3) ตารางตามการคำนวณตามแบบแปลน (ตามแบบแปลน)

$$\rho = \frac{A_s}{b_w d} = 0.004$$

$$\rho' = \frac{A_s'}{b_w d} = 0.004$$

4) ตารางตามการคำนวณตามแบบแปลน (ตามแบบแปลน)

$$P_{max} = \max \left(\frac{1.00}{3.00}, \frac{0.00146}{0.00420} \right) = 0.00146$$

$$P_{lim} = \left(1 - \frac{1}{3} \right) \left(\frac{1}{1 - \frac{1}{3}} \right) \left(\frac{1}{2.00} \right) \left(\frac{1}{0.850} \right) \left(\frac{1}{0.00420} \right) = 0.00146$$

23 design codes, 6 Language Design Report

04

Enhanced Design Code Support

Designing the Future with Innovative Engineering Solutions

AASHTO LRFD 2024 Implementation

Full AASHTO LRFD 2024 Compliance.

- Implementation Design for AASHTO LRFD 2024: The latest requirements are automatically reflected across RC, Steel, Steel Composite, and PSC modules, ensuring full compliance with the 10th Edition.
- Automatic Updates of Design Formulas: Design precision is enhanced by applying new calculation logics for Modulus of Elasticity (E_c), Modulus of Rupture (f_r), and the Concrete Density Modification Factor (λ).
- Modernization of Structural Clauses: The system incorporates updated estimation formulas for tensile strength and revised limit/amplification factors for flange stress and Lateral-Torsional Buckling (LTB).
- Automated Reports with Traceability: Reliability for regulatory submissions is ensured through automatically generated reports documenting all intermediate calculations in compliance with 2024 standards.

The image shows four software interface screenshots for different design modules: Steel Design, RC Design, PSC Design, and Steel Composite Design. Each interface includes a menu bar (Project, View, Structure, Node/Element, Properties, Boundary, Load, Analysis, Results) and a toolbar with icons for Design Type, Design Code, Design Parameters, Modify Steel Material, and Parameter Tables. Below the screenshots is a 'Design Condition' report table.

Design Code	Element	Node(J)	Section
AASHTO-LRFD2024	88	1	Composite

Section Properties

-Gross section		-Transformed section			
	Before	After	Before	After	
H (mm)	1524.00	1720.85	H (mm)	1524.00	1720.85
B (mm)	1257.30	2285.00	B (mm)	1257.30	2285.00
C _{top} (mm)	752.99	376.68	C _{top} (mm)	772.29	404.92
C _{bot} (mm)	771.91	1147.32	C _{bot} (mm)	751.71	1119.08
I _{xx} (mm ⁴)		573.53	I _{xx} (mm ⁴)		601.77
I _{yy} (mm ⁴)		376.68	I _{yy} (mm ⁴)		404.92
A _g (mm ²)	4.639 E+05	9.313 E+05	A _g (mm ²)	5.034 E+05	8.708 E+05
I _x (mm ⁴)	1.397 E+11	2.896 E+11	I _x (mm ⁴)	1.451 E+11	3.073 E+11
S _x (mm ³)	1.856 E+08	7.687 E+08	S _x (mm ³)	1.979 E+08	7.589 E+08
S _y (mm ³)	1.812 E+08	2.524 E+08	S _y (mm ³)	1.930 E+08	2.745 E+08
S _{xx} (mm ⁴)		5.049 E+08	S _{xx} (mm ⁴)		4.812 E+08
S _{yy} (mm ⁴)		7.687 E+08	S _{yy} (mm ⁴)		7.151 E+08

Materials

	f _c (MPa)	E _c (MPa)	t (MPa)	β ₁
Girder	41.369	30772.3	4.053	0.750
Slab	25.000	31475.0	3.151	0.850

Pre-stressing steel information

No.	Tendon	Bond Type	d _s (mm)	A _{ps} (mm ²)	Strength (MPa)	E _p (MPa)	
					f _{pu}	f _{py}	
1	S_T45H2	Bond	930.639	1974.200	1675.427	1861.585	199948.024
2	S_T45H1	Bond	1006.839	1974.200	1675.427	1861.585	199948.024
3	S_T815S2	Bond	1636.268	888.390	1675.427	1861.585	199948.024
4	S_T815S1	Bond	1636.268	888.390	1675.427	1861.585	199948.024
5	S_T815H1	Bond	1275.549	1381.940	1675.427	1861.585	199948.024

Steel Composite Design AASHTO LRFD 2024 Report

comp are	AASHTO 2020	AASHTO 2024
4.5.3.2.2	same	factored moment $M_u = \phi_b M_{20}$
4.5.3.2.2	same	moment magnification $\phi_b = \max(C_1, C_2)$
4.5.3.2.2	same	moment magnification $\phi_b = 1/(1-2P_u/P_c)$
4.5.3.2.2	same	stiffness reduction $\phi_b = 0.75$
4.5.3.2.2	same	Euler buckling $P_c = \pi^2 EI / (K L)^2$
4.5.3.2.2	same	moment magnification $C_1 = 0.6 + 0.4 \lambda$
4.5.3.2.2	same	moment magnification $C_2 = \max(0.75, \lambda)$
5.4.3.1	same	nominal yield strength $f_y = 100$ ksi

SECTION/LATERAL MEMBERS	AASHTO 2020	AASHTO 2024
Flange stress and member bending moment	$f_t \leq 0.6 F_y$ The flange stress f_t may be determined from the order elastic analysis in discrete trace compression flanges for which,	$f_t \leq 0.6 F_y$ The flange stress f_t may be determined from the order elastic analysis in discrete trace compression flanges for which,
2nd order compression flange lateral bending stresses may be approximated by emptying the order values as follows	$f_t \leq \left(\frac{0.85}{1 - \frac{M_u}{M_{cr}}} \right) F_y \geq F_y$ (6.10.1.6-4) or equivalently:	$f_t \leq \left(\frac{0.85}{1 - \frac{M_u}{M_{cr}}} \right) F_y \geq F_y$ (6.10.1.6-4) or equivalently:
2nd order compression flange lateral bending stresses may be approximated by emptying the order values as follows	$f_t \leq \left(\frac{0.85}{1 - \frac{M_u}{M_{cr}}} \right) F_y \geq F_y$ (6.10.1.6-5)	$f_t \leq \left(\frac{0.85}{1 - \frac{M_u}{M_{cr}}} \right) F_y \geq F_y$ (6.10.1.6-5)

AASHTO LRFD 2020 vs 2024

Enhanced Localization for Australia & New Zealand

Maximizing Design Compliance and Precision for Oceania Bridge Projects through Dedicated Australia and New Zealand Design Logic.

- Automated Direct Dynamic Amplification (DDA): Impact Factors for stress and displacement are automatically calculated in compliance with AU/NZ standards. This fundamentally prevents manual input errors.
- Element-Specific Dynamic Rail Factors: AU-standard railway moving load factors are assigned to specific elements or groups without duplicating load cases, significantly enhancing analysis efficiency.

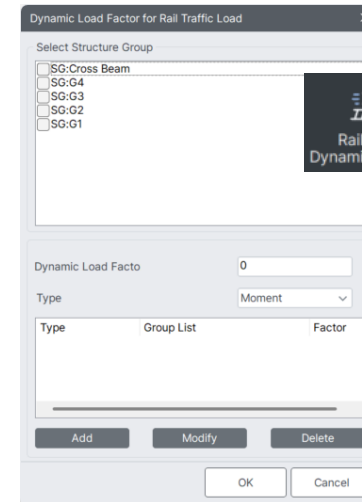

Dynamic Factor by Element

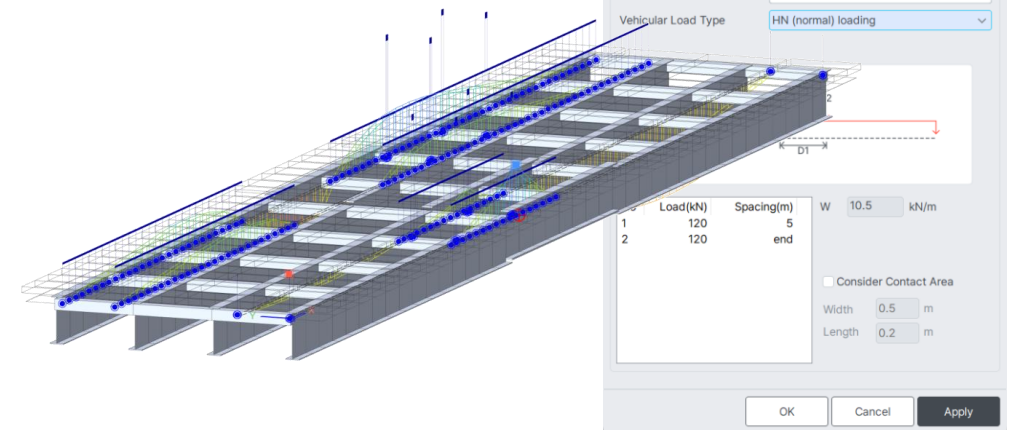

NZ Moving Load



Enhanced Localization for Malaysia

Implementation Malaysia National Annex and Eurocode standards to optimize bridge design compliance and durability.

- Integration of MS EN 1992-2:2022 and NA: Provides a design environment fully compliant with Malaysia's specific RC/PSC bridge requirements, including regional Limit States and Partial Safety Factors.
- Environmental Durability for Local Climates: Shear, torsion, and crack width calculation logic is optimized to reflect Malaysia's high-temperature and humid conditions for enhanced lifecycle management.
- Modernized Workflow (BS to Eurocode): Supports a seamless transition from legacy BS 5400 to the latest Eurocode-aligned package (MS EN 1990-1998).

MALYSIAN STANDARD MS EN 1992-2:2022 (NATIONAL ANNEX:2022)

Malaysia National Annex to MS EN 1992-2:2022, Eurocode 2: Design of concrete structure – Part 2: Concrete bridges - Design and detailing rules

ICS: 93.045, 91.010.30, 91.080.40
Description: concrete structures, concrete bridges, design and detailing rules

© Copyright 2022
DEPARTMENT OF STANDARDS MALAYSIA

Concrete Design Code

Design Code: Eurocode2-2:05

National Annex: Malaysia

Moment Resistance

Moment Redistribution Factor for Beam: 1

Beam Checking

Singly Reinforced Beam

Doubly Reinforced Beam

Column Design

Axial load plus biaxial bending(Fx+My+Mz)

Axial load plus uniaxial bending(Fx+My)

Consider Axial-Moment Interaction for Plate Column

Shear Resistance

Strut Angle for Shear Resistance: 45 Deg

OK Close

Concrete Design Code

MIDAS Information Technology Co.,Ltd. MIDAS CIVIL NX 2026 (v1.21) / Design

MEMBER NAME : SB (Section ID : 1, Element No.2)

1. Member Information

- 1) Design Code
EN 1992-2: 2005 (NA-Malaysia)
- 2) Section Property
SB (ID : 1)
- 3) Material
Concrete
 $f_{ck} = 40.000\text{MPa}$, $E_{cm} = 35,220.000\text{MPa}$
Reinforcement
 $f_{yk} = 400.000\text{MPa}$, $f_{pk} = 500.000\text{MPa}$, $E_s = 200,000.000\text{MPa}$
- 4) Length
L = 10.000m
- 5) Reinforcement Data

Top	5,627.047mm ²	Top	4,061.429mm ²	Top	1,298.289mm ²
Bottom	799.055mm ²	Bottom	799.055mm ²	Bottom	799.055mm ²
Stirrups	2-D10@140	Stirrups	2-D10@140	Stirrups	2-D10@140

2. Moment Capacity (Negative) (Sector I, 0.00R)

	LCB	cLCB2	
Neg. Moment	M_{Ed} / M_{Rd}	600.000kNm / 613.225kNm = 0.978	OK
	$A_{s,min} / A_s \cdot A_{s,max}$	$A_{s,min} = 798.257\text{mm}^2 \leq A_s = 5,627.047\text{mm}^2 \leq A_{s,max} = 16,000.000\text{mm}^2$	OK

*cLCB2 : (1.000) / DeadLoad

1) Design Parameter

$f_{ck} = 40.000\text{MPa}$, $f_{tk} = 400.000\text{MPa}$
 $b_w = 1,000.000\text{mm}$, $h = 400.000\text{mm}$
 $d = 350.000\text{mm}$
 $A_{s1} = 5,627.047\text{mm}^2$
 $\alpha_{cc} = 1.000$

Concrete Design Report



Enhanced Localization for Canada

Maximizing Load Calculation Automation and Curved Bridge Analysis Precision through Latest CSA S6:2025 Standards.

- Braking and Centrifugal Forces (Approach 1): Generate static loads representing Braking and Centrifugal force based on the latest Canadian code from the Moving Load Tracer results.
- Centrifugal Forces (Approach 2): The centrifugal force is treated as a horizontal force that creates an overturning effect, resulting in a couple of vertical loads (weight transfer) on the wheels.

Approach 1

Moving Load Converted to Static Load

Vertical Loads

Centrifugal Forces

Braking Force

Additional Data

Design Speed: m/sec

Radius of Curvature: m

Factor for Centrifugal Force

4/3 (Other than Fatigue) 1.0 (Fatigue)

Direction of Centrifugal Forces with reference to Vehicle Direction

Right-to-Left Direction Left-to-Right Direction

File Name

Approach 2

Traffic Line Lanes

Lane Name:

Traffic Lane Properties

Lane Width: m

Eccentricity: m

Wheel Spacing: m

Centrifugal Force

Left Wheel of Vehicle

Moving Forward: W

Transverse Lane Optimization

Allowable Width: m

Vehicular Load Distribution

Lane Element Cross Beam

Cross Beam Group

Skew

Start: End: [deg]

Moving Direction

Forward Backward Both

Selection by

2 Points Picking Number

m

m

Operations

No	Elem	Eccen. (m)	CE
1	1	-2.775	0.5
2	2	-2.775	0.5
3	3	-2.775	0.5
4	4	-2.775	0.5
5	5	-2.775	0.5

Define Standard Vehicular Load

Standard Name:

Vehicular Load Properties

Vehicular Load Name:

Vehicular Load Type:

No	Load(kN)	Spacing(m)
1	40	3.6
2	100	1.2
3	100	6.6
4	140	6.6
5	120	end

W: kN/m

Increment of Axle Spacing for Variable Length: m

Dynamic Load Allowance

Auto User Input

where only one axle of the CL-W Truck is used

where any two axle, or axles 1,2 and 3 are used

where three axles except for axles 1,2 and 3 or more than three axles are used

Add Centrifugal Forces



Enhanced Localization for Brazil

Optimizing Design for Brazilian PSC Bridges through Latest NBR 6118:2023 Standards.

- Compliance with NBR 6118:2023: Directly incorporates Crack Allowances, Prestress Losses, and SLS/ULS checks for PSC girders. This ensures a design environment fully aligned with the latest Brazilian standards.
- PSC Prestressing Levels (1–3): Defines the structural type as Level 1, Level 2, or Level 3 grades.
- Support for Environmental Exposure Classes: Design constraints, such as minimum cover and strength, are automatically applied based on Exposure Classes (I–IV). This ensures tendon protection and long-term performance.
- Integrated Service Stage Evaluation: Unified analysis for stress, cracking, and deflection is provided across all stages. This strengthens design consistency in accordance with NBR 6118 provision.
- Prestress Loss and Strength Verification: Rigorous tracking of initial and long-term prestress losses is combined with ULS resistance checks for flexure, shear, and torsion to ensure structural safety.



PSC Design Code

05

Enhanced Seismic Analysis

Designing the Future with Innovative Engineering Solutions



Fiber Hinge Support for Pushover Analysis

Enhanced seismic evaluation via Fiber Models, maximizing precision and structural interpretability.

- **Fiber-Based Nonlinearity:** Subdivides sections into concrete and steel fibers to represent material-specific ($\sigma-\epsilon$) relationships, ensuring a high-fidelity analysis environment.
- **Accurate Damage Tracking:** Continuously tracks structural damage from initial yielding to failure. This enhances the reliability of seismic performance evaluations.
- **Direct Sectional Response:** Evaluates reinforcement layouts and confinement effects directly. This eliminates reliance on empirical hinge calibrations.
- **Advanced Distributed Plasticity:** Applies distributed plasticity through fiber hinges to derive section-specific $M-\Phi$ relationships, realistically simulating plastic hinge behavior and energy dissipation.
- **Incremental Post-Yield Tracking:** Updates fiber stress states at each increment to precisely capture rapid strength reduction and softening behavior.
- **Automated Fiber Discretization:** Dedicated UI for fiber subdivision and reinforcement placement optimizes the workflow from section definition to capacity curve generation.
- **Consistent Performance Evaluation:** Uses section-specific data to improve the accuracy of target displacement and performance point estimation.

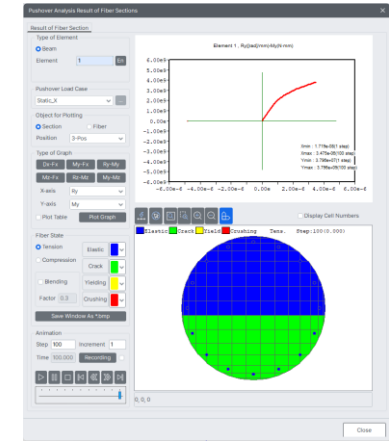
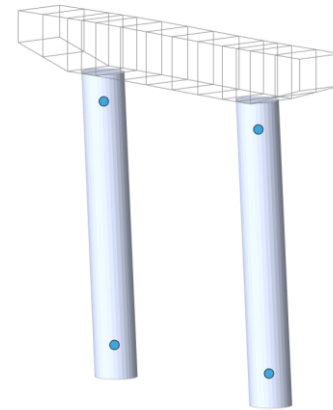

Pushover Curve

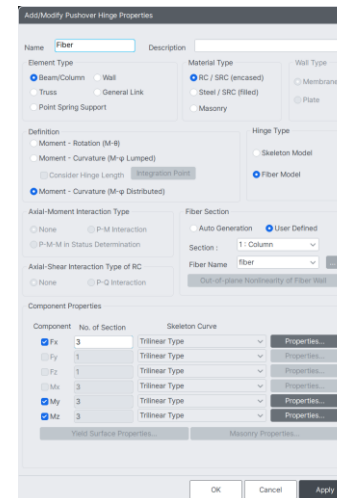

Hinge Properties

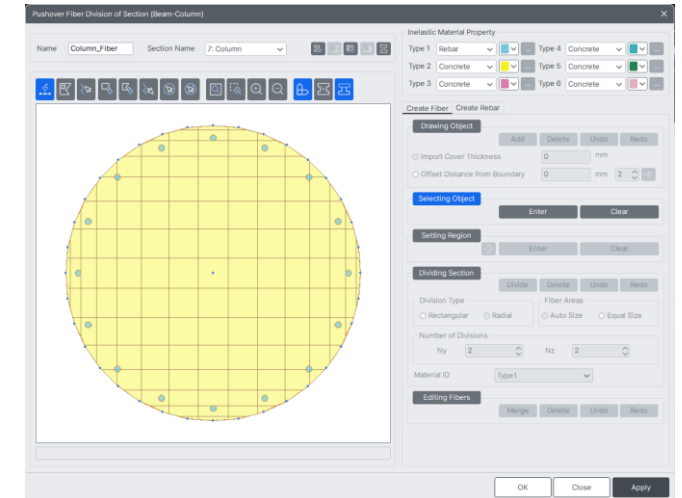

Fiber Division of Section

Enhanced Pushover Curve design spectrum

Enabled user-defined response spectrum input for precise and efficient project-specific seismic evaluation.

- User-Defined Demand Spectrum Input: Supports a customized environment for applying project-specific data to Pushover analysis, moving beyond standard code-based spectra.
- Advanced Spectrum Generation Path: A dedicated "User Type" selection within the interface streamlines the creation and retrieval of custom spectral datasets, improving workflow efficiency.
- Direct Application of Project Data: Performance assessments are performed based on the exact specifications required by each unique project, improving consistency in seismic evaluation.

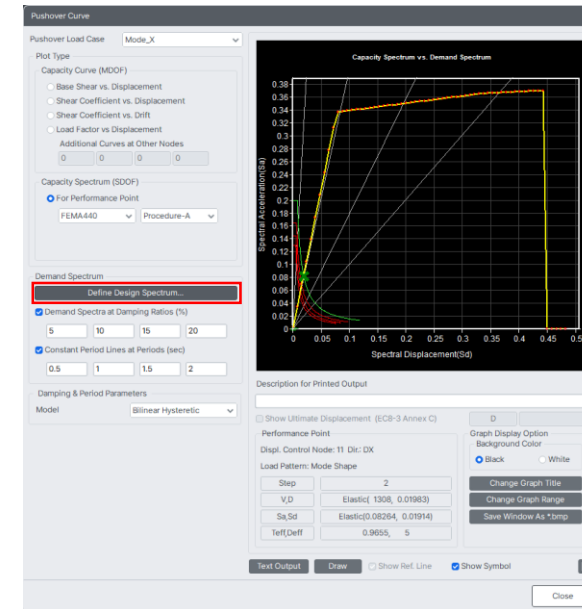

Pushover Curve

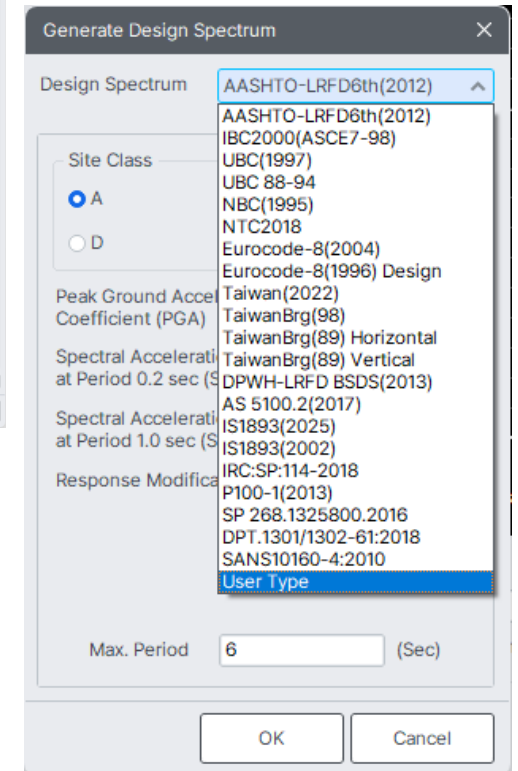

User Type Design Spectrum

Point Spring Support added to Inelastic Hinge Properties

Added Point Spring Support to Inelastic Hinge Properties for precise simulation of non-linear boundary behavior.

- Expansion of inelasticity settings to include Point Spring Support in addition to standard member-based elements (Beam-Column, Truss and General Link).
- Allows for the nonlinear simulation at the support level without needing extra link elements. This enhances the precision of simulating complex boundary conditions, such as bridge bearings or pedestals that exhibit yielding or sliding.

Add/modify inelastic hinge properties

Name :

Description

Element Type

Beam-Column Point Spring Support Truss General Link

Material Type

RC/SRC (encased) Steel/SRC (filled)

Definition

Moment - Rotation (M-Theta) Moment - Curvature (M-Phi Distributed)

Hinge type

Skeleton Model Fiber Model

Interaction type

None P-M in Strength Calculation P-M-M In status determination Parametric P-M (Multi-Curve)

Fiber Section

Auto Generation User Defined

Section

Fiber Name

Component Properties

Component	Hysteresis Model
<input type="checkbox"/> Fx	Kinematic Hardening Properties...
<input type="checkbox"/> Fy	Kinematic Hardening Properties...
<input type="checkbox"/> Fz	Kinematic Hardening Properties...
<input type="checkbox"/> Mx	Kinematic Hardening Properties...
<input checked="" type="checkbox"/> My	Kinematic Hardening Properties...
<input checked="" type="checkbox"/> Mz	Kinematic Hardening Properties...

Yield Surface Properties...

OK Cancel Apply

Inelastic Hinge Properties

Tree Menu Task Pane

Assign Inelastic Hinges

Assign Inelastic Hinges

Option

Add / Replace Delete

Element Type

Beam Truss General Link Point Spring Support

Select Property

hinge

Select 2 Nodes

2 Nodes

Number

Inelastic Hinge Property

point spring

Section

Select All Matching Elements

Import Inelastic Hinge Data

Assign Inelastic Hinges

06

Enhanced Railway Bridge Capabilities

Designing the Future with Innovative Engineering Solutions

Expanded Rail-Structure Interaction Capabilities

Enhanced RSI analysis via automated alignment handling and global DB integration in railway projects.

- **Multi-Curve Alignment Handling:** Supports curved rails on straight girders or transition curves. This ensures the analysis environment corresponds with actual track geometry.
- **Physical Expansion Joint Modeling:** Uses End Distance and Gap parameters for precise joint simulation, reflecting real-world structural behavior.
- **Integrated Global Rail Database:** A built-in library of international gauge standards enables rapid and accurate rail section selection for global projects.
- **Advanced Stiffness Control:** Precisely captures directional behavior via lateral track/bearing stiffness and Beta Angles enabling more accurate representation.
- **Automated Centrifugal Load Calculation:** Automatically calculates centrifugal forces from train speed and live loads, reducing the risk of manual calculation errors.
- **Unified Excel Reporting:** Automatically generates comprehensive Excel reports for stress and LWR axial forces, streamlining technical reviews.
- **Streamlined Workflow for Complex Geometries:** Integrated processing of alignments and expansion joints minimizes errors and reduces modeling effort.

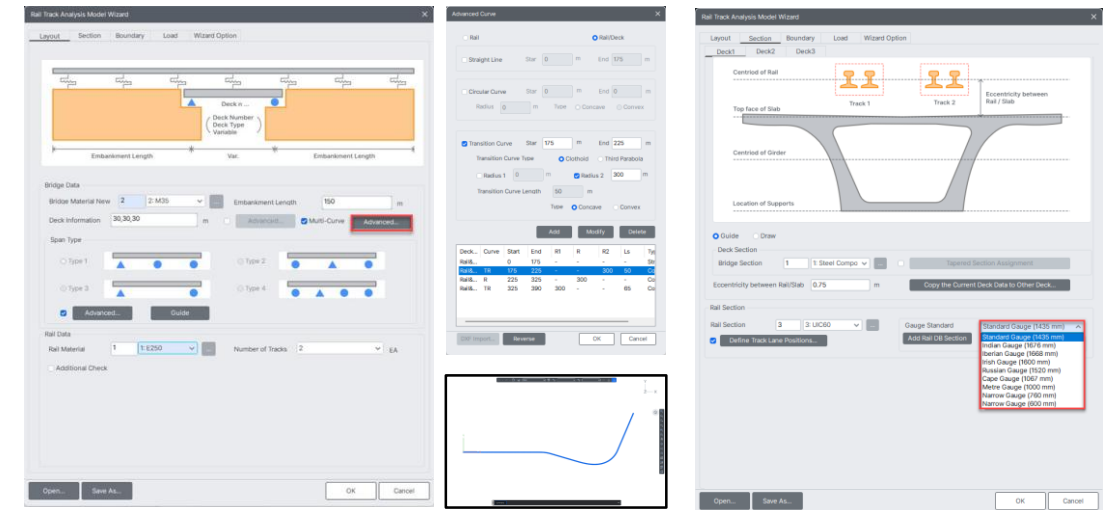

Multi-Curve

Add Rail Database Section

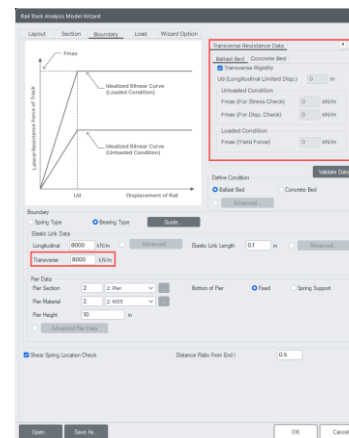

Transverse Stiffness Data

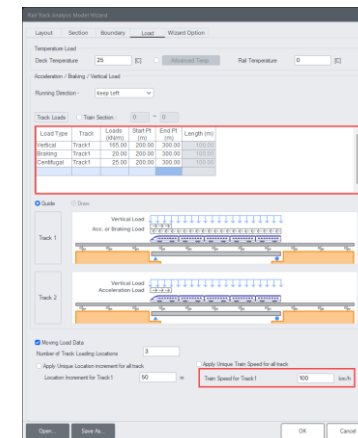

Centrifugal Force



Excel Report

07

Improved Modeling Productivity

Designing the Future with Innovative Engineering Solutions



Tracing-Based Modeling

Maximizing Modeling Speed and Geometrical Precision through Direct CAD Reference and Tracing.

- Drawing-to-Member Generation: Structural members are directly generated by tracing imported CAD lines. This enables a rapid and intuitive modeling environment.
- Integrated Drawing Management: Drawings can be scaled, aligned, and edited within the workspace, eliminating the need for external CAD tools.
- Automatic/Semi-automatic Mapping: Users select reference lines for mapping instead of manual coordinate entry, reducing input time and human error.
- Automated Centerline Extraction: Member centerlines are generated directly from CAD sources, precisely reflecting the original design intent.
- Unified Workspace Workflow: Managing drawing preparation and model generation in one place minimizes preprocessing time and prevents redundant rework.
- Guaranteed Geometric Consistency: Modeling directly from original drawing data eliminates inconsistencies and omissions common in manual conversion.
- Reduced Manual Data Entry: Automating coordinate input and member generation frees engineers to focus on model verification and analysis configuration.

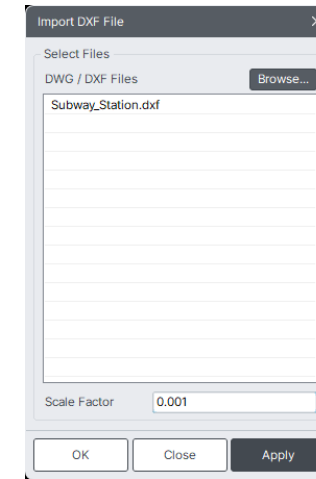

Import DXF

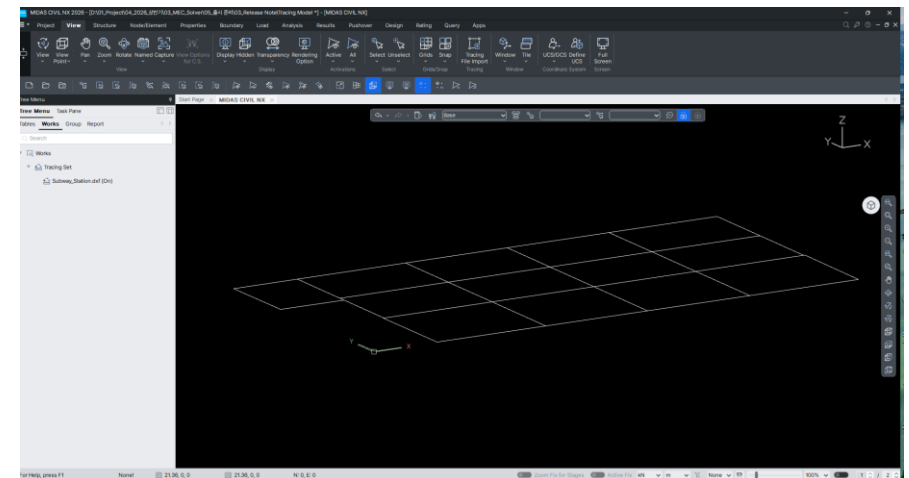

Create Tracing Set



Refined Element Type Classification for More Intuitive Local Axis Definition

Element classification in Change Element Parameters for Element Local Axis update has been subdivided from 2 types into 8 types.

- In the previous version, the Element Local Axis function in Change Element Parameters was broadly classified into only two categories: Frame and Planar.
- In CIVIL NX 2026 (v2.1), these categories have been refined for greater clarity and usability. The Frame category has been subdivided into Truss, Tension Only / Hook / Cable, Compression Only / Gap, and General Beam / Tapered Beam. The Planar category has also been separated into Plate, Plane Stress, and Plane Strain. In addition, Solid elements, which use a different axis system from 2D elements, can now have their local axes redefined based on GTC or UCS coordinates.
- With this enhancement, local axis definitions can now be applied more precisely according to each element type, while also improving the usability of 3D elements, whose previous local axis settings were less intuitive.

Tree Menu Task Pane
Node Element Boundary Mass Load

Change Element Parameters

Start Number
Node Number 35531
Element Number 51428

Parameter Type
 Material ID
 Section ID
 Thickness ID
 Element Local Axis
 Element Type
 Reverse Element Local
 Align Element Local

Mode
Element Type Frame
 Assign
 Beta Angle
 Ref. Point
 Ref. Vector
 Beta Angle 0 [Deg]
 Coordinate Dir.
 Local Axis
 Local-x Local-y
 Direction
 Coordinate Dir. +Z
 Origin Point [ft]
 Change
 Angle Increment 0 [Deg]

Previous Version

Tree Menu Task Pane
Node Element Boundary Mass Load

Change Element Parameters

Start Number
Node Number 7010
Element Number 6133

Parameter Type
 Material ID
 Section ID
 Thickness ID
 Element Local Axis
 Element Type
 Reverse Element Local
 Align Element Local

Mode
Element Type Plate
 Assign
 Beta Angle
 Ref. Point
 Ref. Vector
 Beta Angle 0 [Deg]
 Coordinate Dir.
 Local Axis
 Local-x Local-y
 Direction
 Coordinate Dir. +Z
 Origin Point [m]
 Change
 Angle Increment 0 [Deg]

Mode
Element Type Solid
 GCS Ref. Axis
 GCS

CIVIL NX 2026 (v2.1)

Customization of Message Window and Toolbar

Maximizing Immersion and Interface Efficiency through Personalized Workspace Customization.

- **Dual-Mode Message Display:** Supports bottom-anchored Docked Mode and standalone Floating Mode. This enables flexible screen configurations for multi-monitor setups and personal preferences.
- **Intuitive Mode Management:** A user-friendly interface allows seamless toggling between modes via Radio Buttons in Preferences, simplifying environment control.
- **Command Input Optimized Layout:** Provides a fixed mode for direct command entry and a detached mode to maximize viewport space, ensuring an uninterrupted workflow.
- **Instant Verification via Status Bar:** The current mode is instantly displayed in the Status Bar, providing immediate visual confirmation of environment changes.
- **Persistent Environment Settings:** The system automatically restores the user's preferred mode upon restarting, ensuring a consistent and stable workspace.
- **Workflow Stabilization:** Fixing the window position eliminates unnecessary resizing and separates the modeling area from information panels, reducing operational overhead.
- **Expanded Multi-Monitor Flexibility:** Improves readability by allowing the message window to be placed on a separate screen, minimizing interference during complex modeling.

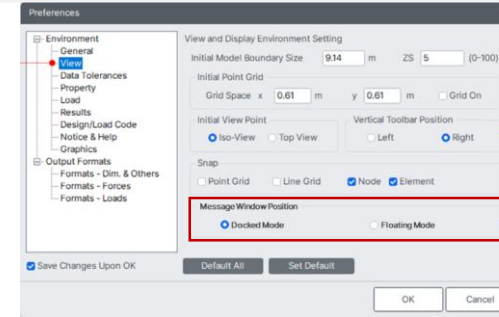

Message Window Position

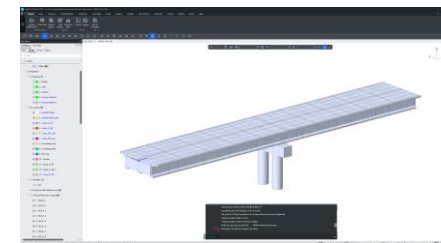
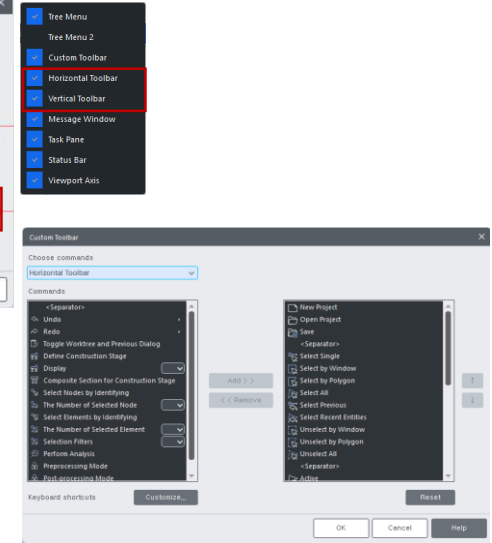

Floating Mode

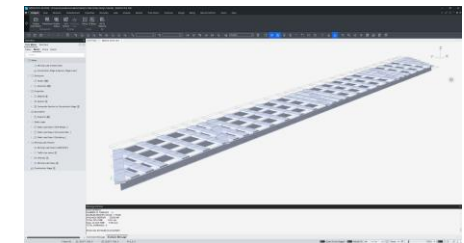

Docked Mode

08

Performance Improvements

Designing the Future with Innovative Engineering Solutions



Performance Improvement

Up to 10x faster Open/Save & graphics and 840x faster post-processing — revolutionizing your workflow.

- **File Open/Save and Data Structure Optimization:** Asynchronous Open/Save and data compression have been introduced to resolve disk-write bottlenecks. This reduces Open/Save times for gigabyte-level (GB) model files by more than 4x.
- **Graphics Computation and Visualization Efficiency:** View manipulation logic for large-scale models has been improved through optimized pipelines and multi-core distribution. This enhances responsiveness during rotation, zooming, and panning by more than 10x.
- **Result Retrieval Algorithm Optimization:** Memory mapping technology now enables instant access to analysis databases, eliminating indexing delays. This accelerates post-processing speeds by 5x to 840x, fundamentally resolving bottlenecks during massive result reviews.

[Optimization of incremental iteration algorithms]

Static/Eigenvalue/Time History Analysis

DOF: 8,904
Equations: 3,456
Iteration: 120,000

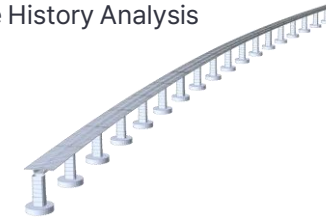

CIVIL NX 2025:		CIVIL NX 2026 :
2,281.04s	90.2%↓	224.39s

[Parallel processing optimization for multiple load cases]

Static/CS /Moving Load Analysis

DOF: 5,028
Equations: 3,082

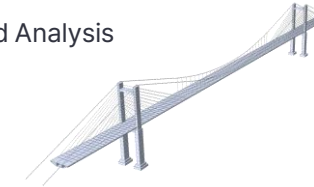

CIVIL NX 2025:		CIVIL NX 2026 :
61.86s	63.1%↓	22.83s

[Enhancement of sparse matrix solver efficiency]

Static Analysis

DOF: 200,583
Equations: 181,278

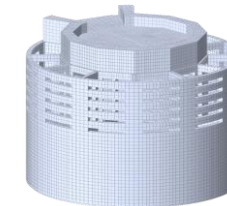

CIVIL NX 2025:		CIVIL NX 2026 :
96.52s	26.7%↓	70.77s

Interpretation Progress PC Specification Information

CPU: 11th Gen Intel(R) Core(TM) i9-11900H @ 2.50GHz

RAM: 31.7GB (Used: 20.6GB, Available: 11.0GB)

GPU: NVIDIA GeForce RTX 3060 Laptop GPU, Intel(R) UHD Graphics

File Open/Save speed

Redesigned I/O architecture to a single-process structure, reducing large-scale model file latency from 18s to 4s.

- Simplified Data Transfer and Bottleneck Removal: Repetitive calculation logic within data transfers has been streamlined, resolving bottlenecks during long sessions. This resulted in a 4x+ speed improvement in file input/output processing.

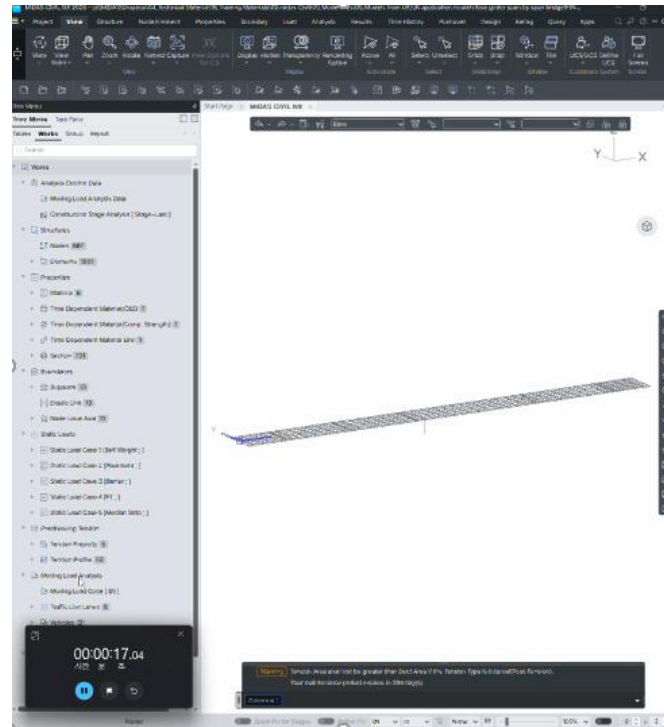

MIDAS CIVIL NX 2025 (v2.1)

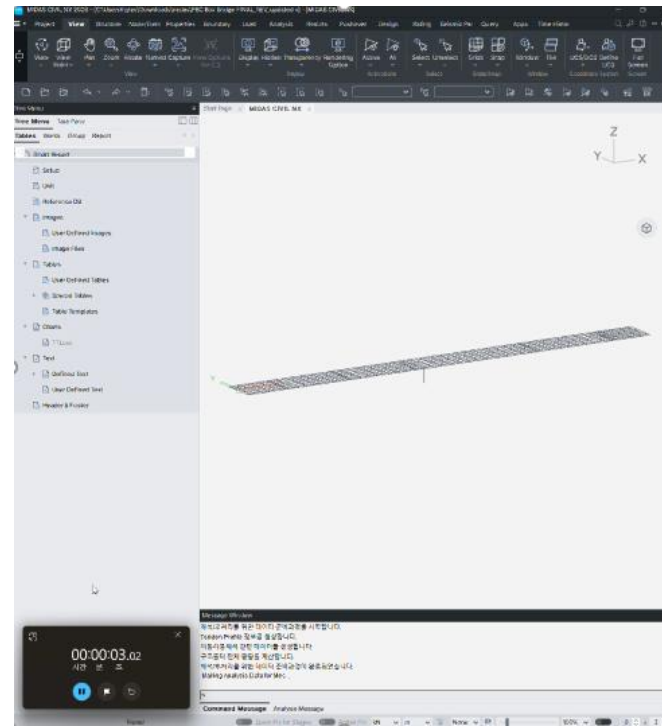

MIDAS CIVIL NX 2026 (v2.1)

File Open Error Skip System

Implemented a Skip System to isolate damaged segments and prevent file loading halts, ensuring seamless model opening.

- Selective Isolation of Data Errors: The file-loading structure has been improved to prevent entire project failures caused by specific corrupted data segments. Accessibility is improved by skipping detected error points and loading all other normal data to minimize downtime.

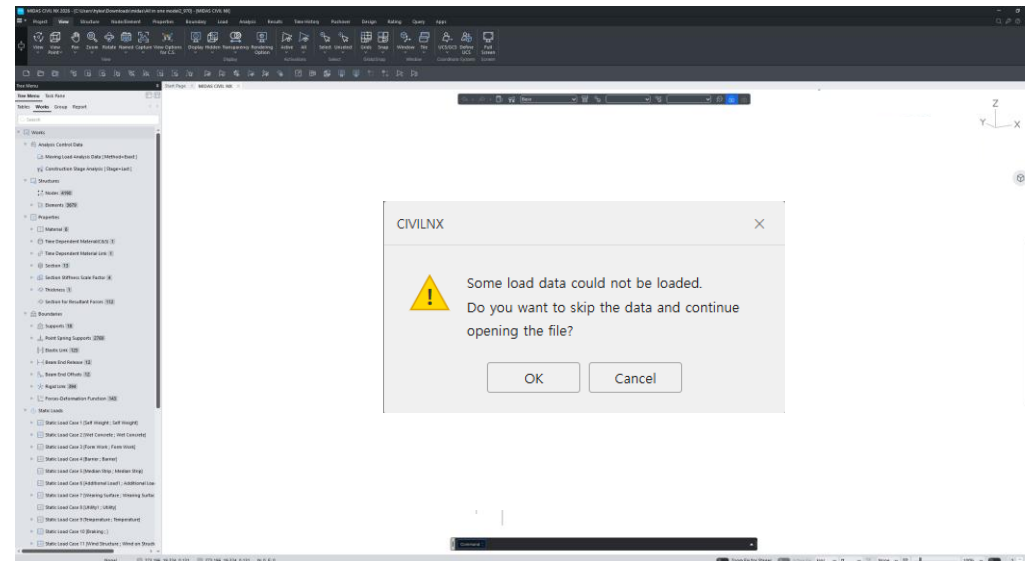
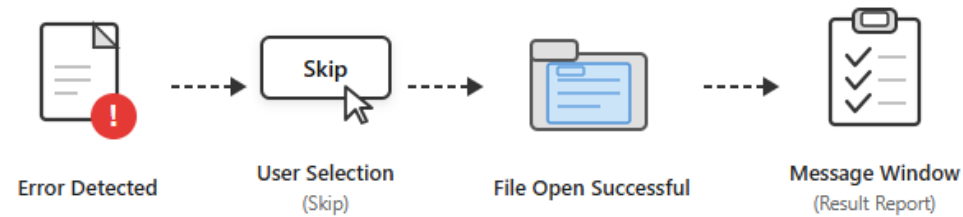

View Selection

Utilized view selection caching to accelerate screen responsiveness by up to 10x for large-scale models with 100k+ elements.

- Elimination of Redundant Computations via Caching: A "Compute once, reuse often" logic has been implemented to minimize recalculations during element or property selection. This drastically reduces selection wait times, particularly in large-scale models.
- Optimized View Selection and Screen Refresh: Computational loads triggered by view transitions-such as filtering and member group selection-are now replaced with memory caching. This improves system response speeds by up to 10x.
- Computational Stability for Massive Datasets: Performance reliability is verified even in extreme environments with over 100,000 elements. The system is optimized to ensure a smooth, lag-free operating environment even in high-density, worst-case scenarios.

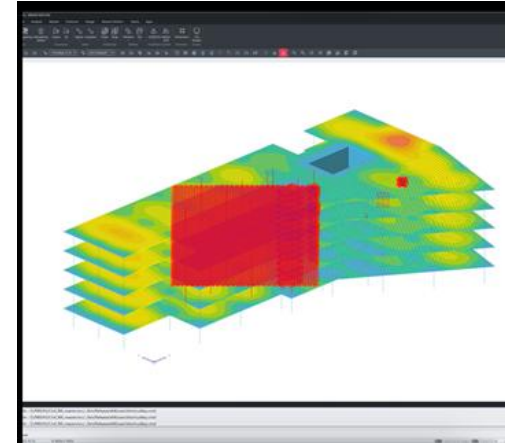

Previous

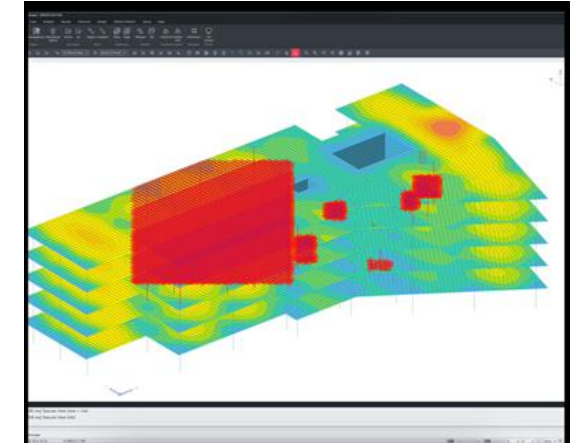

MIDAS CIVIL NX 2026 (v2.1)

Performance Improvement Results

**10x Faster Response
Speed**



View Performance Expansion

Universal Cache and 4K Legend Scaling boost display speed and readability

- Extended Label-Based Operations: Caching functionality has been expanded to all label-based operations, optimizing screen updates by omitting unnecessary recalculations.
- Accelerated Pressure Load Visualization: With optimized algorithms, pressure load data processing speeds have been increased by 300% (3x) compared to previous versions.
- Display-Adaptive UI Optimization: An automatic adjustment algorithm now tailors font and legend sizes to user resolution. By transitioning to a variable scaling system, visibility issues on high-resolution monitors are resolved while reducing screen rendering overhead.
- Enhanced 4K/UHD Visibility: High-readability legends ensure clear technical communication during meetings or reports on 4K/UHD screens.

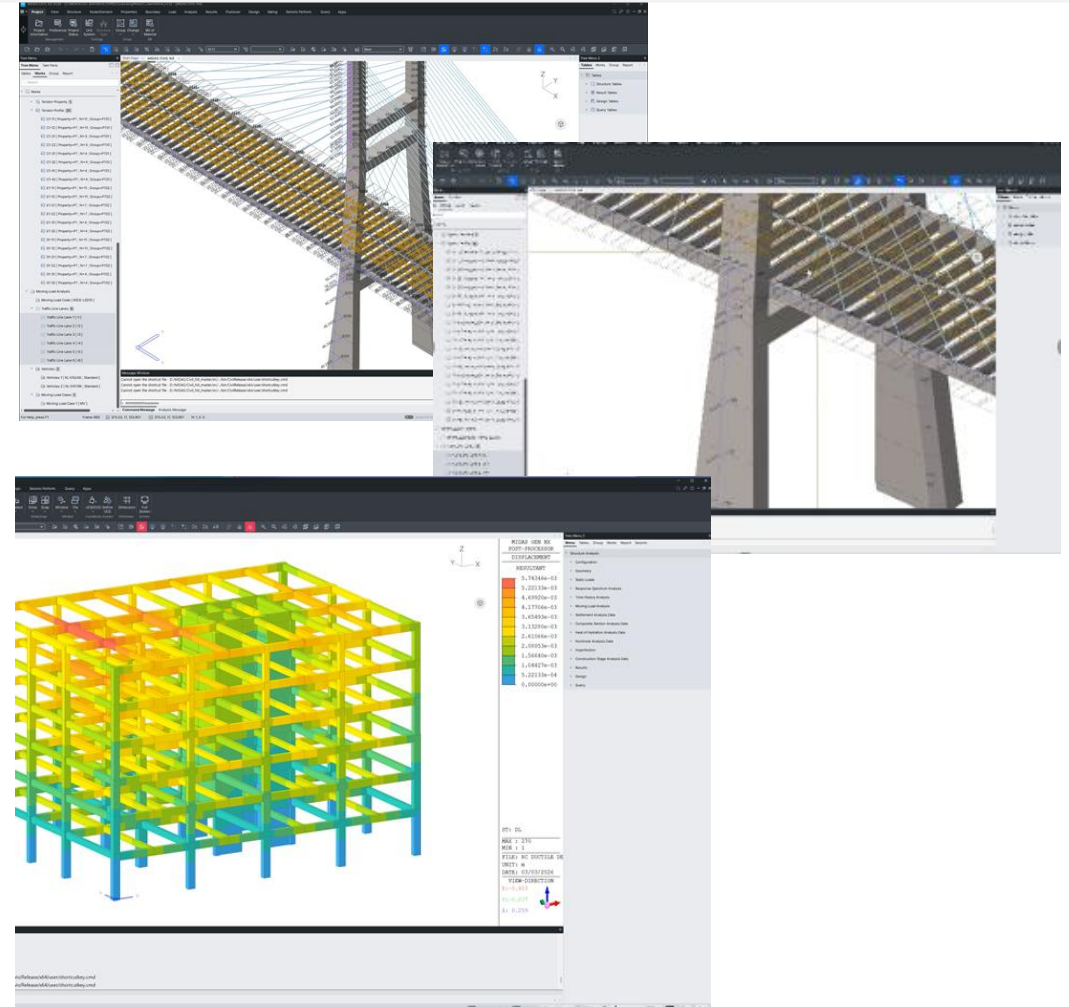

Result Table Performance and Active Dialog Improvement

Faster post-processing and auto-saved dialog settings improve speed and workflow efficiency.

- Accelerated Table Execution: Improved data processing logic for large-scale results, reducing loading times for Beam Force tables from 41s to 7.82s (5x faster).
- Near-Instant Unit Conversion: Optimized internal calculations to achieve an 840x faster response during unit changes, slashing wait times from 21s to 0.025s.
- High-Speed Data Sorting: Enhanced sorting algorithms now process large datasets 89.4x faster, reducing execution time from 28s to 0.32s.
- Elimination of Repetitive Selection: When reopening a table, previous selections for Load Sets, Elements, and Parts are automatically restored.
- Streamlined Workflow: The new process eliminates the need to manually reselect items, allowing work to continue immediately after reopening a table.

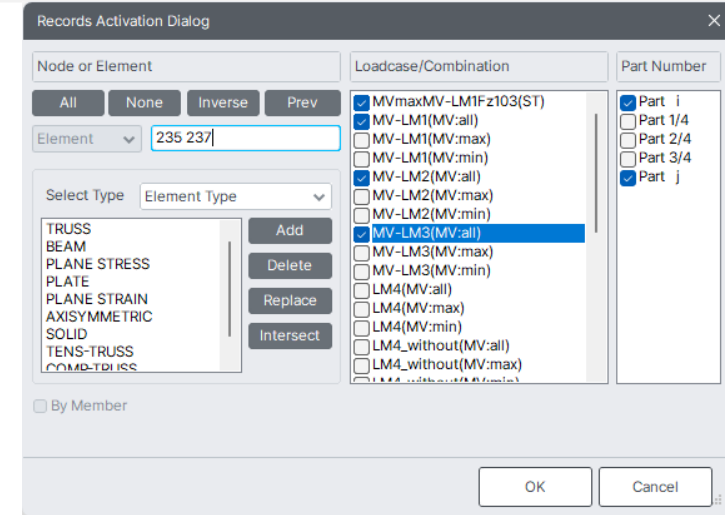

Records Activation Dialog

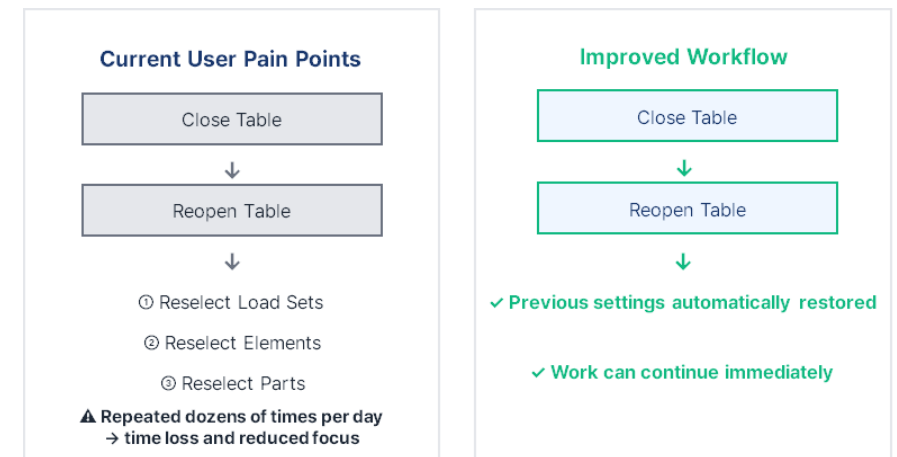

09

Convergence & Nonlinear Control

Designing the Future with Innovative Engineering Solutions

Numerous convergence-related options added to Main Control

Expanded Main control Data: Classical formulas for plate/solid, cable initial state reflection, and tendon-driven section updates.

[Classical Formula Option for Plate and Solid Elements]

- Feature: Option to determine which plate/solid element type is used in the analysis
 - Check On: Apply the conventional element formulation
 - Check Off: Apply the Hybrid element formulation
- The hybrid approach uses a combination of different numerical models when handling in-plane and out-of-plane deformations.
- Applied methods:
 - In-plane: Mixed method
 - Out-of-plane: ANS (Assumed Natural Strain) + Mixed method
- Advantages of the hybrid element:
 - Prevention of locking: When analyzing thin plate structures, shear locking may occur, causing the structure to behave artificially stiffer than it actually is. The hybrid formulation effectively mitigates this issue.
 - Balance of accuracy and efficiency: As noted below, the use of hybrid or mixed methods enables highly accurate results while maintaining computational efficiency.
 - Stabilization of energy modes: It prevents spurious zero-energy modes that may occur in reduced integration of quadrilateral elements, thereby improving the reliability of the analysis results.

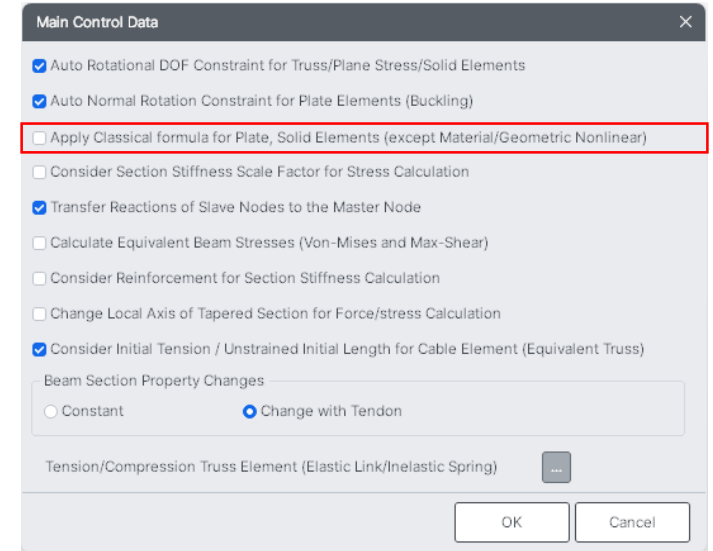

Main control Data

Numerous convergence-related options added to Main Control

Expanded Main control Data: Classical formulas for plate/solid, cable initial state reflection, and tendon-driven section updates.

[Initial State Consideration for Cable Elements (Equivalent Truss)]

- Feature: Option to determine the tangent stiffness calculation method of cable elements when used in linear static analysis
 - Check Off: Apply the conventional equivalent truss element stiffness
 - Check On: Apply the enhanced equivalent truss element stiffness
- The difference lies in how the initial stiffness is defined for iterative convergence calculations.
 - Conventional: The initial stiffness for iteration is based on the truss element stiffness (EA/L), and from the subsequent steps, the tensile force obtained from the first iteration is applied.
 - Enhanced: The initial stiffness is determined based on the unstrained length specified for the element, and from the subsequent steps, the tensile force obtained from the first iteration is applied.
- Advantages of the enhanced method:
 - Convergence stability: When the initial stiffness used in iteration closely reflects the actual state of the cable (tensioned or sagging), the tensile force obtained after the first iteration is closer to the true solution. This not only improves convergence speed but also prevents divergence in highly nonlinear cable analysis.
 - Consideration of pretension effects: The enhanced method starts with knowledge of the initial tension state of the cable through the unstrained length. As a result, the calculation proceeds with stiffness that reflects the actual tension state from the first iteration, enabling more accurate prediction of tension distribution.

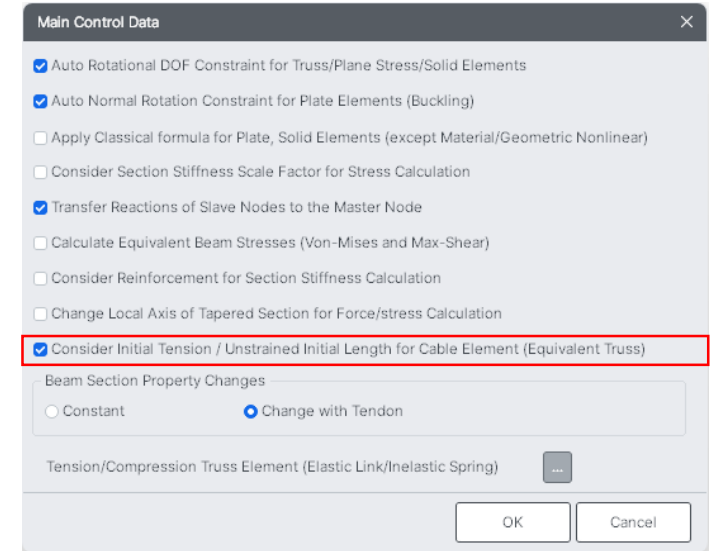

Main control Data

Numerous convergence-related options added to Main Control

Expanded Main control Data: Classical formulas for plate/solid, cable initial state reflection, and tendon-driven section updates.

[Beam Section Property Changes and Nonlinear Control]

- Feature: Option to define the section property application method for prestressed concrete sections
 - Constant: Apply gross section properties
 - Change with Tendon: Apply transformed section properties considering tendons
- This option was previously available only for construction stage analysis. It is now also applicable to models without construction stages when tendons are included.

[Tension/Compression-only Truss Element (Elastic Link/Inelastic Spring)]

- Users can now specify the number of increments (≥ 1) to apply the total load in multiple steps and review results at each step.
- Convergence criteria have been extended to include Load and Work in addition to Displacement.
- Advanced Nonlinear Settings have also been introduced to improve convergence performance.

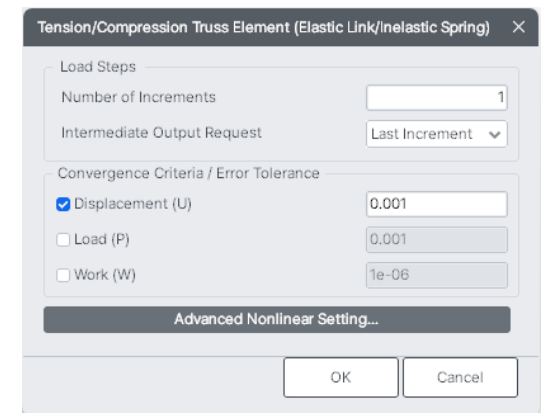
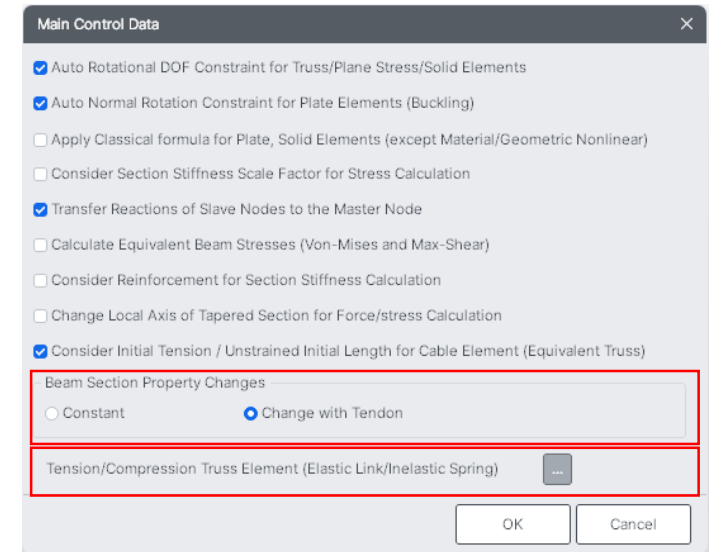

Enhanced Convergence Control for Non-linear CS Analysis

Refined CS analysis with convergence options for geometric non-linear simulation of cable structures.

- Advancement of Non-linear Analysis Control: Detailed convergence criteria based on displacement, force, and energy norms have been introduced, alongside Intermediate Output Requests for each load step. This significantly improves the non-linear convergence success rate for geometric & material nonlinear construction stage analysis.

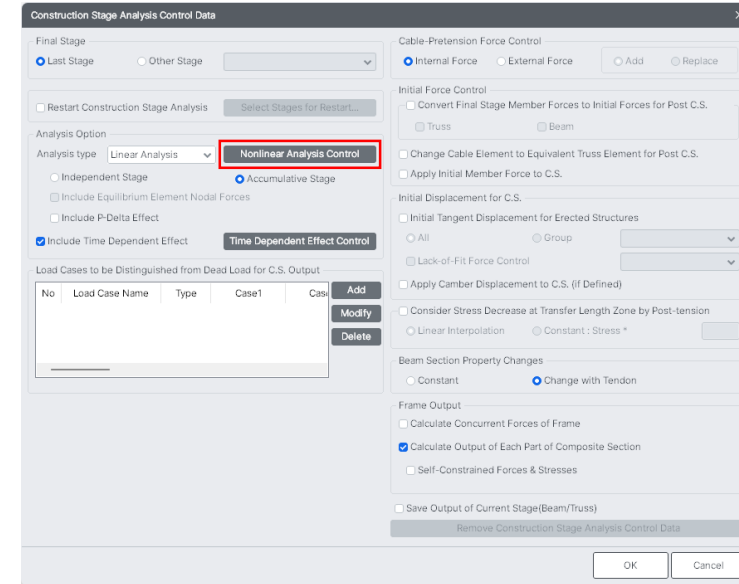

Construction Stage analysis control

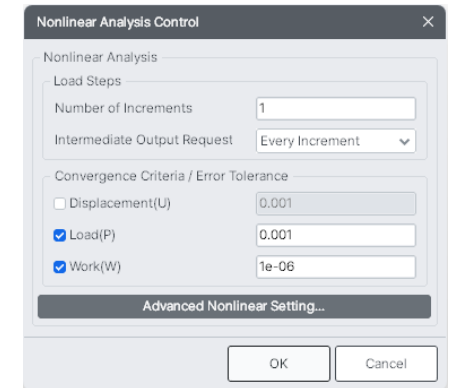

Nonlinear analysis control

Added convergence-related options for Heat of Hydration.

Improved thermal analysis reliability via Multi-Norm convergence criteria.

[Multi-Criteria Convergence for Improved Convergence]

- Feature: Implementation of Multi-Norm convergence checks (Displacement, Load, and Work).
- Key Detail: Beyond simple displacement checks, this approach ensures a rigorous equilibrium state by verifying force and energy balance simultaneously, eliminating misleading results in complex nonlinear thermal models.

Heat of Hydration Analysis Control

Final Stage
 Last Stage
 Other Stage

Initial Temperature 20 [C]

Element Stress Evaluation
 Center Gauss Nodal Point

Creep & Shrinkage

Type
 Creep
 Shrinkage
 Creep & Shrinkage

Creep Calculation Method
 General
 Effective Modulus

$E_{eff}(t) = \phi(t) \times E(t)$
phi1 0.73 t < 3 day(s)
phi2 1 t > 5 day(s)

Use Equivalent Age by Time & Temperature
 Include Selfweight Load
Self Weight Factor -1

Max. No. of Iterations per Increment 50

Convergence Criteria / Error Tolerance

<input type="checkbox"/> Displacement(U)	0.001
<input checked="" type="checkbox"/> Load(P)	0.001
<input checked="" type="checkbox"/> Work(W)	1e-06

Remove Hydration Analysis Data

OK Cancel

Heat of Hydration Analysis Control



Enhanced Control for Time History Analysis: New Time Integration Option and Refined Convergence Criteria

Refined time integration option and iteration controls for non-linear analysis to improve convergence and precision.

[Continuity of Dynamic History (Keep Final Step Accelerations)]

- Feature: Addition of the "Keep Final Step Accelerations" option.
- Key Detail: Carries over the final acceleration from the previous stage to the next, ensuring a continuous dynamic history (Displacement, Velocity, and Acceleration) and eliminating physical gaps in responses during sequential loading.

[P-Delta Effects in Time History Analysis]

- Feature: Direct integration of P-Delta options within the Time History load case settings.
- Key Detail: Accounts for stiffness changes due to axial loads, allowing for more accurate capture of secondary moments during seismic or wind events.

[HHT Algorithm for Numerical Time Integration]

- Feature: Introduction of the Hilber-Hughes-Taylor (HHT) alpha-method for time integration.
- Key Detail: Provides controllable numerical damping to filter out high-frequency noise and unstable oscillations, significantly stabilizing nonlinear models and offering more flexible integration options compared to the standard Newmark method.

Time History load case

Enhanced Pushover Analysis Controls and Convergence Options

Enhanced Pushover analysis with P-Delta and large displacement options for precise non-linear simulation.

- Enhanced Convergence Options for Pushover Analysis

New options have been added to improve convergence performance in Pushover Analysis. Users can now apply advanced solution controls such as Stiffness Update Scheme (Full Newton-Raphson, etc.), Bisection, and Line Search methods. Parameters for iteration count, divergence threshold, and tolerance are also provided for difficult nonlinear cases.

- Improved Control of P-Delta and Large Displacement Effects

Previous Version: Large Displacement could only be defined in Global Control, while P-Delta effects could only be assigned by load case.

CIVIL NX 2026 (v2.1) : Both P-Delta and Large Displacement can now be defined in Global Control or individually for each load case. This provides a more consistent and intuitive setup workflow.

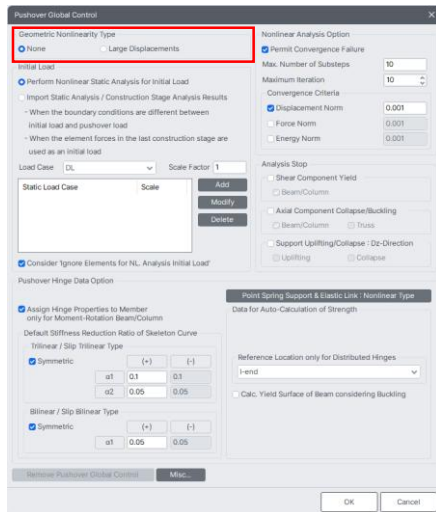

Previous

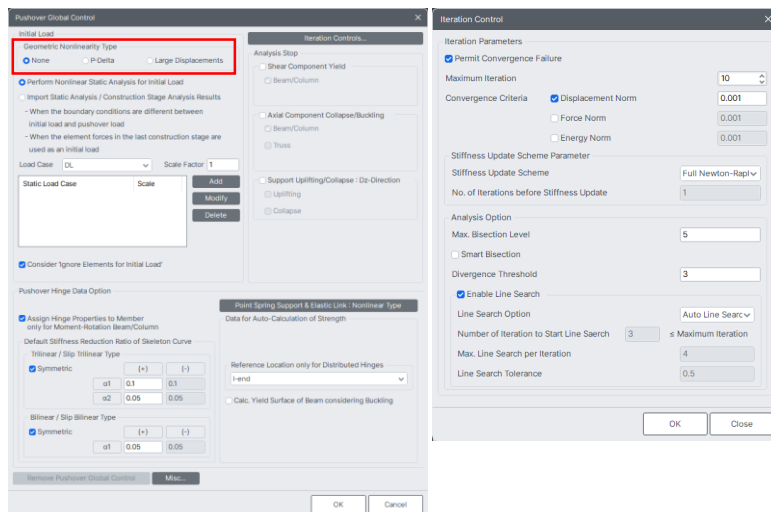

CIVIL NX 2026 (v2.1)

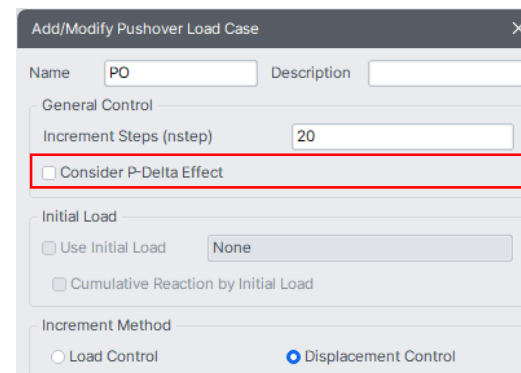

Previous

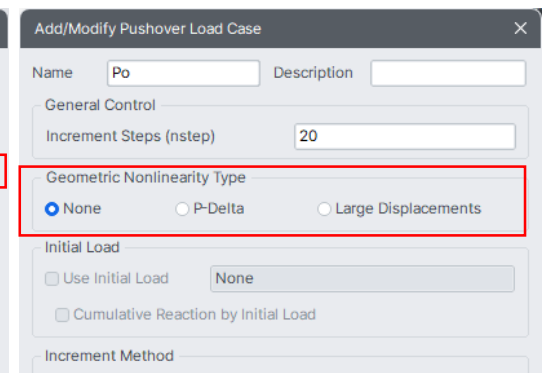

CIVIL NX 2026 (v2.1)

Added multi-processor and equation solver options in Analysis Option.

Optimized multi-processor and solver settings to maximize hardware performance and accelerate large-scale model analysis.

• Intelligent Equation Solver Selection

Solver options have been updated to Auto or Multi-Frontal Sparse. In Auto mode, a Dense Solver is used for small models, while larger models automatically switch to Multi-Frontal Sparse for optimal speed and memory efficiency.

• Full-Process Parallelization for Faster Analysis

Previous : Parallel processing was limited to specific stages such as selected solving procedures (e.g., Multi-Frontal Solver) and certain post-calculation tasks like moving load combination results. Core stiffness and internal force calculations were primarily executed in a single thread.

CIVIL NX 2026 (v2.1) : Multi-threading is now applied across the entire analysis workflow, regardless of analysis type. Structural stiffness assembly, internal force calculations, and result generation are all parallelized for significantly improved performance.

• Memory-Optimized Architecture for Large-Scale Models

Previous : Element stiffness, load data, and intermediate calculations were mainly processed through temporary file-based I/O, regardless of available system memory.

CIVIL NX 2026 (v2.1) : Available system memory is actively utilized for calculations, minimizing disk I/O dependency. Systems with larger memory capacity achieve greater performance gains, especially for large-scale models.

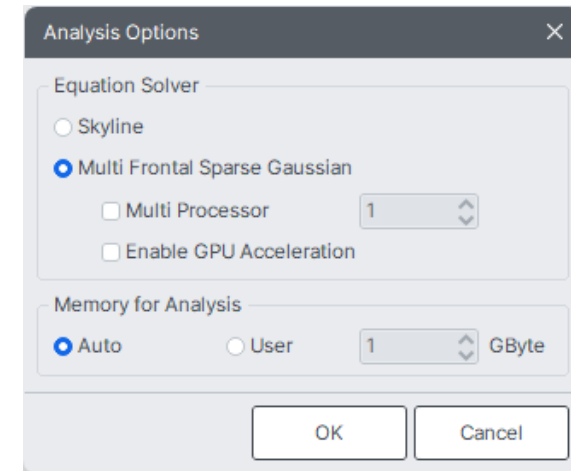

Previous Version

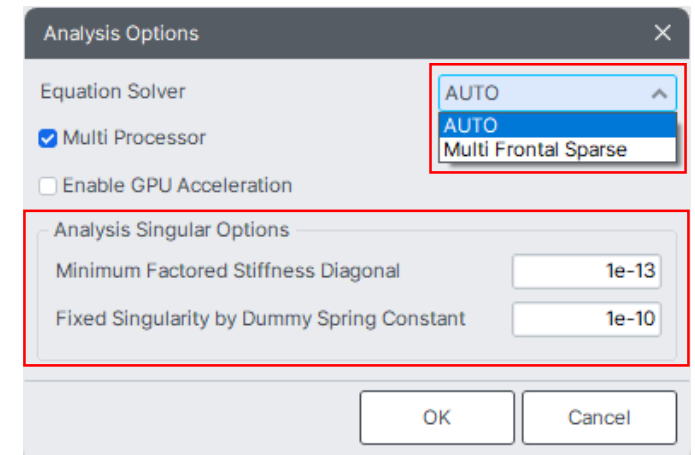

CIVIL NX 2026 (v2.1)

Improved Lumped Mass Options in the Structural Type settings

Refined Lumped Mass Settings with Clearer Mass Center Selection

- Previous Version: For Lumped Mass, the Consider Off Diagonal Masses option controlled several different behaviors, which could be difficult to interpret.
 - When enabled, off-diagonal mass matrix terms were included in the mass calculation.
 - For members with Section Offset, mass was correctly considered at the centroid, regardless of the offset location.
 - For models with Rigid Links, mass was distributed to all connected nodes when enabled but concentrated only at the master node when disabled.
- CIVIL NX 2026 (v2.1): Mass-related options have been reorganized for clearer and more accurate dynamic analysis settings.
 - For Section Offset, users can now directly choose whether the lumped mass is applied at the Centroid or the Offset Position through intuitive option names.
 - For Rigid Links, nodal mass distribution is now always considered automatically, equivalent to the previous version with Consider Off Diagonal Masses enabled.
 - The Consider Rotational Rigid Body Mode for Modal Participation Factor option is now always active, ensuring rotational components are included in modal participation factor calculations.
- These improvements provide a clearer workflow and more reliable results for vibration and seismic analysis.

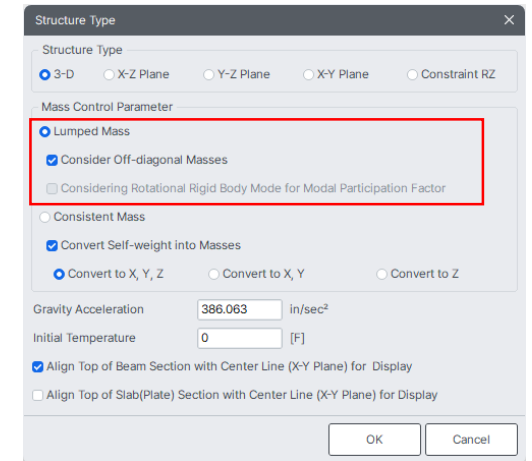

Previous Version

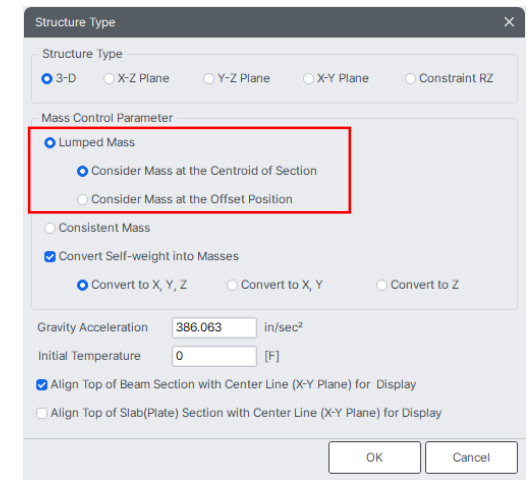

CIVIL NX 2026 (v2.1)

10

Property Separation for Selective Analysis

Designing the Future with Innovative Engineering Solutions

Separated Inelastic Hinge Properties for General Links

Enhanced intuitiveness via a dedicated menu for assigning inelastic hinges directly to General Links

- In the previous version, when assigning an Inelastic Hinge to a General Link, both linear and inelastic properties had to be defined together.
- In CIVIL NX 2026 (V2.1), with the introduction of Selective Analysis, the linear and inelastic properties of General Links can now be defined and modified independently. Accordingly, inelastic properties can now be assigned separately through the Assign Inelastic Hinges function.

The screenshot shows the 'Boundary' task pane. The 'Inelastic Hinge Property' section is highlighted with a red box. It contains a checkbox labeled 'Inelastic Hinge Property' which is currently unchecked. Below the checkbox is a text input field with the value 'Inelastic Hinge' and a dropdown arrow.

Previous Version

The screenshot shows the 'Assign Inelastic Hinges' task pane. The 'General Link' and 'Select Property' options are highlighted with a red box. The 'General Link' option is selected with a radio button. Below it, the 'Select Property' option is also selected with a radio button, and a dropdown menu shows 'hinge' as the selected property.

Assign Inelastic Hinge

Independent Output Control Section in Time History Global Settings

Dedicated TH output menu for selective data extraction, reducing unnecessary resource consumption and accelerating post-processing.

- Independent Output Control Menu: Output settings have been separated from Global Control into a dedicated Output Option window. This allows users to directly control whether step-by-step results for inelastic hinges and fiber sections are stored.
- Selective Extraction of Analysis Data: Output can now be generated only for user-selected elements and stages, significantly reducing result file loading times after analysis. It also prevents unnecessary file size increases compared with full-element output methods.
- Detailed Results for Damping and Isolation Devices: Energy result output options have been subdivided for specific devices such as viscous/steel dampers and isolators. This improves report generation efficiency and supports more targeted deliverables for seismic and vibration control design.

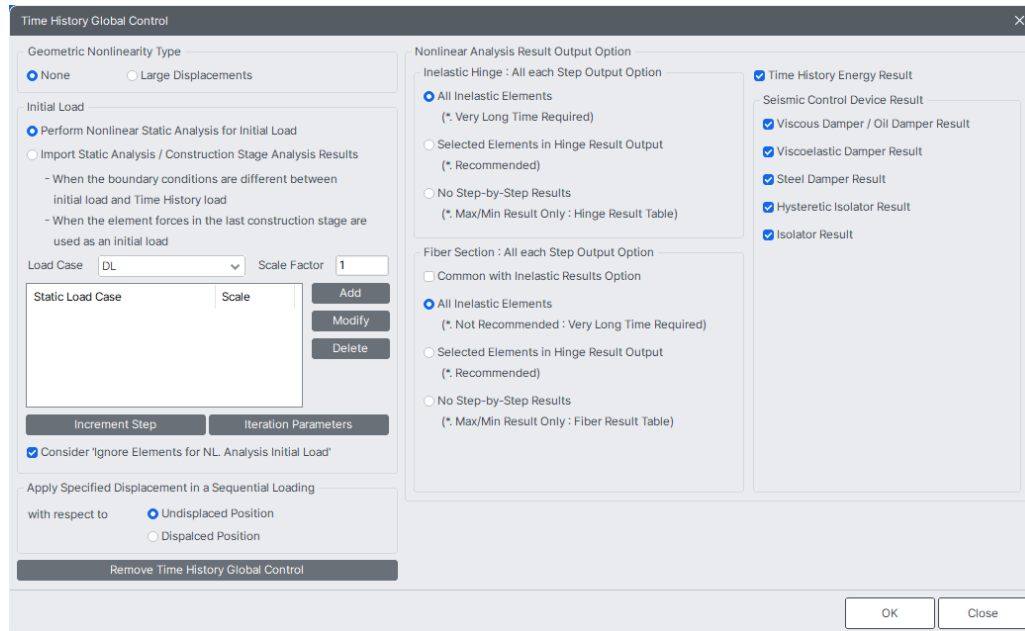

Previous Version

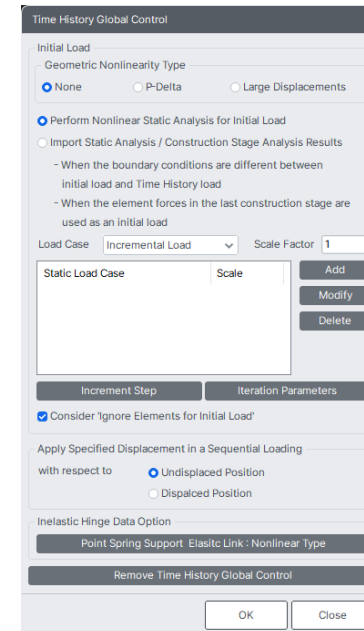

Time History Global Control

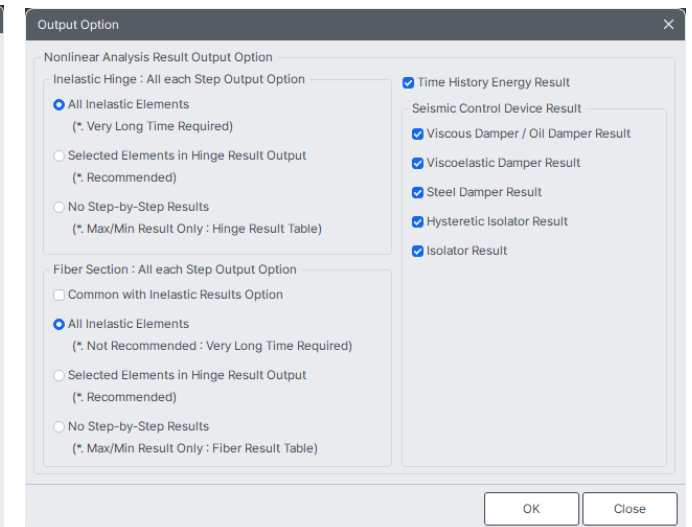

Output Option



Automatic Fiber Section Generation with Dedicated Inelastic Material Link

Inelastic Material Link for Auto Generation to streamline Fiber Model Input

- In the previous version, inelastic material properties for fiber models could be defined within the Material Property function. In the new version, this has been improved so that inelastic properties can be managed independently from linear material properties, enabling more efficient setup for Selective Analysis.
- By using the Inelastic Material Property for Auto Generation function, inelastic materials such as confined/unconfined concrete, rebar, and steel can be linked with corresponding linear material properties.

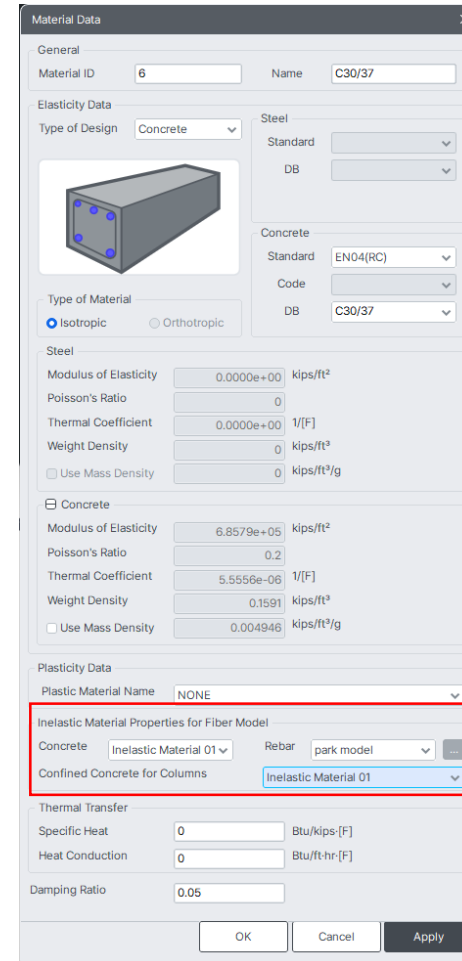

Previous Version

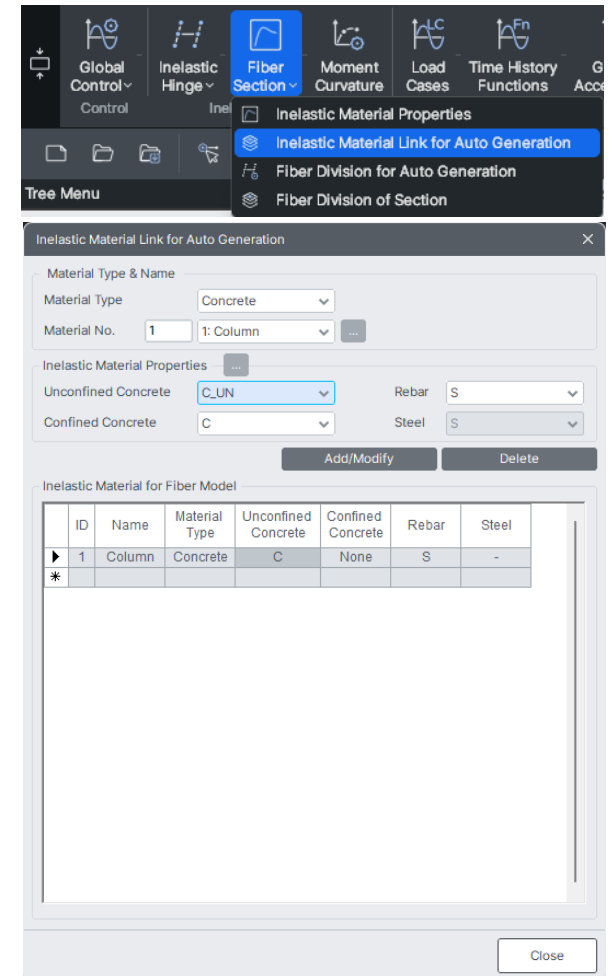

CIVIL NX 2026 (v2.1)



Automatic Fiber Section Generation with Dedicated Inelastic Material Link

Inelastic Material Link for Auto Generation to streamline Fiber Model Input

- Once Inelastic Material Link for Auto Generation is entered, selecting Auto Generation for the Fiber Section in the Add/Modify Inelastic Hinge Properties dialog and defining the Fiber Division for Auto Generation will automatically generate the Fiber Division for Section data.
- Previously, users had to manually define the number of divisions and assign materials for each fiber section. With this enhancement, fiber sections can now be generated automatically, significantly improving efficiency in preparing nonlinear analysis inputs.

Add/Modify Inelastic Hinge Properties

Name: fiber

Description:

Element Type: Beam-Column, Point Spring Support, Truss, General Link

Material Type: RC/SRC (encased), Steel/SRC (filled)

Definition: Moment - Rotation (M-Theta), Moment - Curvature (M-Phi Distributed)

Interaction type: None, P-M in Strength Calculation, P-M-M in status determination, Parametric P-M (Multi-Curve)

Fiber Section (highlighted in red): Auto Generation, User Defined

Section: 21 : G1

Fiber Name: fiber

Component Properties:

Component	No. of Sections	Hysteresis Model
<input checked="" type="checkbox"/> Fx	3	Kinematic Hardening
<input type="checkbox"/> Fy	3	Kinematic Hardening
<input type="checkbox"/> Fz	3	Kinematic Hardening
<input type="checkbox"/> Mx	3	Kinematic Hardening
<input checked="" type="checkbox"/> My	3	Kinematic Hardening
<input checked="" type="checkbox"/> Mz	3	Kinematic Hardening

Buttons: OK, Cancel, Apply

Add/Modify Inelastic Hinge Properties

Fiber Division for Auto Generation

Data for Strength Auto-Calculation of Hinges

Reference Location for Distributed Hinges: Beam, Center, J-End

Fiber Model Option: Beam-Column

Consider Reinforcement Area

Number of Divisions for Auto Generation:

Core:

Fiber Areas: Auto Size, Equal-Size

Ny (y-dir): 15, Nz (z-dir): 15

Cover:

Fiber Areas: Auto Size, Equal-Size

Ny (y-dir): 15, Nz (z-dir): 15

Buttons: OK, Cancel

Fiber Division for Auto Generation

Inelastic Material Link for Auto Generation

Material Type & Name: Concrete

Material Type: Concrete

Material No.: 1, T: Column

Inelastic Material Properties: C_LIN, C

Rebar: S, Steel: S

Inelastic Material for Fiber Model:

ID	Name	Material Type	Unconfined Concrete	Confined Concrete	Rebar	Steel
1	Column	Concrete	C	None	S	-

Buttons: Add/Modify, Delete, Close

Inelastic Material Link for Auto Generation

Auto-generation

Fiber Division of Section

Name: B1_fiber, Section Name: 10T: C1(1-3F)

Inelastic Material Property:

Type 1: C, Type 2: S, Type 3: C, Type 4: C, Type 5: C, Type 6: C

Buttons: Create Fiber, Create Rebar

Drawing Object: Add, Delete, Undo, Redo

Selecting Object: Enter, Clear

Setting Region: Enter, Clear

Dividing Section: Divide, Delete, Undo, Redo

Division Type: Rectangular, Radial

Fiber Areas: Auto Size, Equal Size

Number of Divisions: Ny: 2, Nz: 2

Material ID: Type1

Editing Fibers: Merge, Delete, Undo, Redo

Buttons: OK, Close, Apply

Fiber Division for Section